



Research Centre on
ZERO EMISSION
NEIGHBOURHOODS
IN SMART CITIES

THERMAL ENERGY SYSTEMS IN ZEN

Review of technologies relevant for ZEN pilots

ZEN Report No. 3 – 2018



Acknowledgement

This report has been written within the Research Centre on Zero Emission Neighbourhoods in Smart Cities (FME ZEN). The authors gratefully acknowledge the support from the Research Council of Norway, the municipalities of Oslo, Bergen, Trondheim, Bodø, Bærum, Elverum and Steinkjer, Sør-Trøndelag county, Norwegian Directorate for Public Construction and Property Management, Norwegian Water Resources and Energy Directorate, Norwegian Building Authority, ByBo, Elverum Tomteselskap, TOBB, Snøhetta, ÅF Engineering AS, Asplan Viak, Multiconsult, Sweco, Civitas, FutureBuilt, Hunton, Moelven, Norcem, Skanska, GK, Caverion, Nord-Trøndelag Elektrisitetsverk - Energi, Numascale, Smart Grid Services Cluster, Statkraft Varme, Energy Norway and Norsk Fjernvarme.



Research Centre on
ZERO EMISSION
NEIGHBOURHOODS
IN SMART CITIES

ZEN Report No. 3

Harald Taxt Walnum and Eyvind Fredriksen (SINTEF Building and Infrastructure)

Thermal energy systems in zen

Review of technologies relevant for ZEN pilots

Keywords: Low temperature district heating, Thermal storage, Combined Heat and Power
ISBN 978-82-536-1579-0

Norwegian University of Science and Technology (NTNU) | www.ntnu.no

SINTEF Building and Infrastructure | www.sintef.no

<https://fmezen.no>

Abstract

This report reviews state-of-the-art on thermal energy systems for neighbourhoods. Main focus is on technologies related to 4th generation district heating (4GDH), biomass combined heat and power (CHP) systems, ground source heat pumps (GSHP) and seasonal heat storage. See the Executive Summary for a thorough overview.

Executive Summary

This report reviews state-of-the-art on thermal energy systems for neighbourhoods. Main focus is on technologies related to 4th generation district heating (4GDH), biomass combined heat and power (CHP) systems, ground source heat pumps (GSHP) and seasonal heat storage.

Thermal networks

The development of large-scale district heating system and energy production units are not within the scope of ZEN. However, thermal networks will be an integral part of the energy system in the ZEN pilots, and the concept of 4GDH can be transferred into smaller local networks, either isolated, or coupled to a larger grid. Stepwise integration of new or renovated neighbourhoods with thermal networks fitted to the 4GDH concept is also an important part in the transition to the next generation district heating system.

The main focus in the 4GDH concept is to reduce the temperature levels in the network. Reduced temperatures has several important benefits.

- Reduced heat loss
- Increased production efficiency
- Increased possibilities for surplus heat recovery

With reduction in energy consumption in modern buildings, the heat density will be reduced. Therefore it is important with measures to reduce the heat losses from district heating networks. Reducing the temperatures in the pipes is the most effective method to reduce heat losses. Most renewable energy sources will benefit from a lower water temperature, both through increased production capacity and improved efficiency. For both solar collectors and heat pumps, the performance factors are directly linked to the temperature level. Also biomass condensing boilers and CHP will benefit from lower temperatures. There are also challenges with reducing temperatures, in addition to the minimum temperature demand from the existing building stock, there are issues related to pipe capacity and risk of legionella in domestic hot water (DHW) systems that needs to be considered.

In many cases, new or renovated developments, designed for low temperature district heating (LTDH) are connected to an existing district heating network. In such cases the connection should be designed to benefit the existing network. An example of this is to utilize the return line of the existing network as heat source for the LTDH network.

The substation is an important part for ensuring lowest possible return temperature in the thermal network. There exists several advanced substation designs with high theoretical performance, but experience shows that more effort should be put in dimensioning and designing well-functioning substations and secondary networks, than inventing advanced connection schemes. For apartment buildings, individual substations in each flat (flat stations) have been a popular solution for LTDH networks, due to reduced legionella risk. For very low temperature systems, concepts with local temperature boosters for DHW have been studied. The most effective solution is found to be instantaneous electric heating. However, this gives very high peak loads, and should be evaluated against the use of a storage tank with the accompanying heat loss.

Another part of the 4GDH concept, is the use of local energy sources, both renewable sources (solar) and surplus heat. Depending on the temperature level, there are several possibilities for connecting distributed sources. The most common and with the highest potential is a return-supply (RS)

connection, where water from the return line is heated to the supply temperature and pumped into the supply line. There are several examples of successful utilization of distributed heat sources, however, it is important to consider how to secure a stable connection for both pressure and temperature.

Ground source heat pumps and seasonal storage

Geothermal heat, and especially ground source heat pump (GSHP) systems, have become steadily more popular in the Nordic countries. By the end of 2015, the total capacity in Europe was more than 20 GW_{th}, distributed in over 1,7 million installations. 90 % of the installations in Norway are closed loop boreholes with heat pumps. The efficiency and cost of borehole heat exchangers (BHE) are dependent on local geological conditions, but there is some research on reducing the borehole thermal resistance. Especially interesting is the concept with an annulus type collector with studies showing about 50 % reduction in borehole resistance.

The main benefits of GSHP systems are in situations with a balance between heating and cooling demands. This makes the system especially interesting for neighbourhood applications, with a mix of building categories. The most common solution is to have individual GSHP systems for each building, or set of connected buildings. In a neighbourhood context this may be a central heating and cooling plant connected to a borehole field, distributing hot and cold water through a piping network. An alternative concept is to use the collector circuit to distribute energy in the neighbourhood, and use distributed heat pumps to boost the temperature. The main characterization of such systems are the ability to use the heat demand for some buildings, to supply efficient cooling for other buildings throughout the year, through a single set of pipes. The ability to adjust the temperature level to the needs of individual buildings is a large benefit for neighbourhoods with existing building stock.

Seasonal thermal energy storage (STES) can be applied for systems where there are seasonal offsets between thermal energy production capacity and demand. For seasonal storage, latent heat systems are most relevant, due to the large scale. STES is a complex and high cost solution for improved energy efficiency, and is only recommended for systems where other simpler measures are already implemented or not feasible. The connected systems should be designed to fit the STES system, focusing on low temperatures, high temperature differences between supply and return, and minimising peak loads.

CHP

Most of the installed combined heat and power (CHP) capacity worldwide is within large scale power plants, but with the increased focus on energy efficiency over the past years, small and micro scale CHP, below 2 MW and 100 kW, respectively, has experienced considerable growth. Micro scale CHPs are typically installations for single family houses whereas small scale CHP can play a part in local thermal grids in the Zero Emission Neighbourhood.

Within the ZEN scope only fuels with very low or no CO₂-emissions are relevant. In a Norwegian context biomass and biogas are the most cost-effective alternatives to this day.

The CHP technologies reviewed in this report are:

- Reciprocating internal combustion engines
- Micro gas turbines
- Organic Rankin Cycle (ORC)
- Stirling engines
- Fuel cells

Reciprocating internal combustion engines and micro gas turbines rely on combustion of a fuel for electricity generation and utilize the thermal combustion energy for heating purposes. ORCs and Stirling engines are on the other hand closed cycles where working fluids generate electricity by externally supplied heat. Fuel cells are producing electricity through the electrochemical reaction between hydrogen and oxygen.

The different technologies have different characteristics regarding cost-effectiveness, part load ability, power ranges and efficiencies. Due to relatively low investment costs and current fuel and energy prices, the reciprocating internal combustion engine is the most widespread alternative for small and micro CHP today. In a ZEN perspective both ORC and Stirling engines can have a future due to their ability to utilize low temperature waste heat. Fuel cells have been considered to be relatively expensive for several years, and this seems to be the case still. Their need for very pure fuels, in order not to significantly reduce fuel cell component lifetime, makes it necessary with additional cleaning processes if they are to be run on biogas.

The CHP is highly flexible in its operation (daily modulation thanks to heat storage), and since its electricity generation follows the heat demand (higher in winter) it offers a good complement to PV in terms of equalizing the energy exchange between a neighbourhood and the grid.

Contents

Abstract	3
Executive Summary	4
Thermal networks.....	4
Ground source heat pumps and seasonal storage	5
CHP	5
1 Introduction	9
2 Thermal networks - 4 th generation district heating systems.....	11
2.1 Main characteristics	12
2.1.1 Temperature levels	12
Challenges with low temperatures	15
2.2 Implementing low temperature district heating.....	16
2.3 Technical solutions	17
2.3.1 Piping and insulation	18
2.3.2 Connections between existing DH system and new LTDH network	19
2.3.3 Substations and consumer connection.....	20
2.4 Examples of low temperature projects	24
2.4.1 Lystrup, Denmark (Olsen, Christiansen et al. 2014)	24
2.4.2 Sønderby, Denmark(Olsen, Christiansen et al. 2014)	25
2.4.3 Østre Hageby, Stavanger (Line 2013)	26
2.5 Decentralized and distributed sources and building interaction	26
2.5.1 Prosumers	26
2.5.2 Connection principles.....	27
2.5.3 Examples	28
3 Ground source heat pump systems and seasonal storage.....	32
3.1 Shallow geothermal heat with heat pumps	32
3.1.1 Components.....	32
3.1.2 Systems and energy balance	34
3.1.3 Dimensioning of borehole fields	39
3.1.4 Cost.....	42
3.2 High temperature seasonal heat storage	43
3.2.1 Systems for seasonal storage	43
3.2.2 Important parameters for the connected thermal network.....	47
3.2.3 Examples	48
4 Small scale CHP	52
4.1 CHP technology status.....	52
4.1.1 Reciprocating engines	53

4.1.2 Gas turbines	53
4.1.3 Organic Rankine Cycle (ORC).....	53
4.1.4 Stirling engine	54
4.1.5 Fuel cells.....	55
4.2 Financial aspects.....	55
4.3 Widespread CHP: The Danish model.....	56
4.4 CHP in a ZEN perspective.....	56
4.5 Case studies	58
4.5.1 Campus Evenstad	58
4.5.2 ORC South Tyrol.....	59
4.6 CHP technology summary.....	60
5 Conclusion.....	61
6 References	62

1 Introduction

The Research Centre on Zero Emission Neighbourhoods in Smart Cities (FME ZEN Centre) will enable the transition to a low carbon society by developing sustainable neighbourhoods with zero greenhouse gas emissions. The Centre will speed up decarbonisation of the building stock (existing and new), use more renewable energy sources and create positive synergies among the building stock, energy, ICT and mobility systems, and citizens.

This report is a part of Work Package 4 Energy Flexible Neighbourhoods, Task 4.1 Local thermal grids, generation and storage. The goal for WP 4 is to develop knowledge, technologies and solutions for design and operation of energy flexible neighbourhoods. Task 4.1 especially focuses on the thermal solutions.

In ZEN there are seven pilot areas: Campus Evenstad, Ydalir (Elverum), Steinkjer, Trondheim Kunnskapsaksen, Furuset, Zero Village Bergen and Bodø – Airport redevelopment.

The ZEN project memo "ZEN pilot survey - WP4 Energy flexible neighbourhoods" gives an overview of which pilots will develop or use thermal networks (fjernvarme or nærvarme) for heating and cooling distribution, and what technologies are relevant. The survey shows that the following technologies are most relevant for the ZEN pilots:

1. Thermal networks
2. Biomass Combined Heat and Power
3. Ground source heat pumps systems and thermal storage

This report reviews state-of-the-art on technologies for 4th generation district heating (4GDH) in a local area network context. The 4GDH technologies and concepts are directly transferable to smaller neighbourhood networks, as most of the challenges are similar. In addition, smaller neighbourhood thermal networks are suitable for piloting and testing of relevant technologies. Smaller thermal networks design as 4GDH can also be connected to existing district heating network and thereby be part of the networks evolution to 4th generation.

Ground source heat pump (GSHP) systems have been increasingly popular as heating and cooling source for individual buildings. The main advantages of GSHP systems manifest themselves with a balance between heating and cooling demand. This makes the solution attractive for neighbourhood applications, with the possibility to integrate the heating and cooling demand in multiple buildings, in addition to surplus heat sources, into a common GSHP system.

GSHP systems are in principle a low temperature energy storage with heat pumps to lift the temperature to an applicable level. Many renewable energy and waste heat sources have a mismatch between production capacity and heat demand from buildings. They typically have a constant capacity throughout the year, or even a peak capacity outside the heating season (solar collectors). This makes solutions for seasonal storage of high temperature energy attractive. This report discusses the most relevant concepts for energy storage and shows some relevant examples of installed systems.

An important part of the ZEN concept is to produce electricity from renewable sources, both for own consumption and for export, to compensate for emissions during the project lifetime. Combined heat and power (CHP) can be an efficient way to produce both heat and electricity for the neighbourhood. An important advantage of CHP systems, compared to solar PV systems, is the ability to produce high amounts of electricity also during winter. Different relevant technologies for CHP systems at neighbourhood scale are discussed in the report.

2 Thermal networks - 4th generation district heating systems

The first district heating networks were introduced in USA in the 1880s, based on distribution of pressurised steam (Lund, Werner et al. 2014). Since, the 1st generation systems have evolved towards lower distribution temperature and higher energy efficiency into today's 3rd generation technology. Figure 2.1 gives a graphical overview of the development of the district heating system, and introduces the concept of 4th generation district heating (4GDH).

4GDH is a concept that tries to describe how the district heating system needs to evolve to adjust to the future energy system, and be a competitive solution in the future sustainable energy systems. The definition of the 4GDH has been developed by the international research center 4DH, based in Denmark (4DH 2017).

The 4th Generation District Heating (4GDH) system is defined as a coherent technological and institutional concept, which by means of smart thermal grids assists the appropriate development of sustainable energy systems. 4GDH systems provide the heat supply of low-energy buildings with low grid losses in a way in which the use of low-temperature heat sources is integrated with the operation of smart energy systems. The concept involves the development of an institutional and organisational framework to facilitate suitable cost and motivation structures. (4DH 2017)

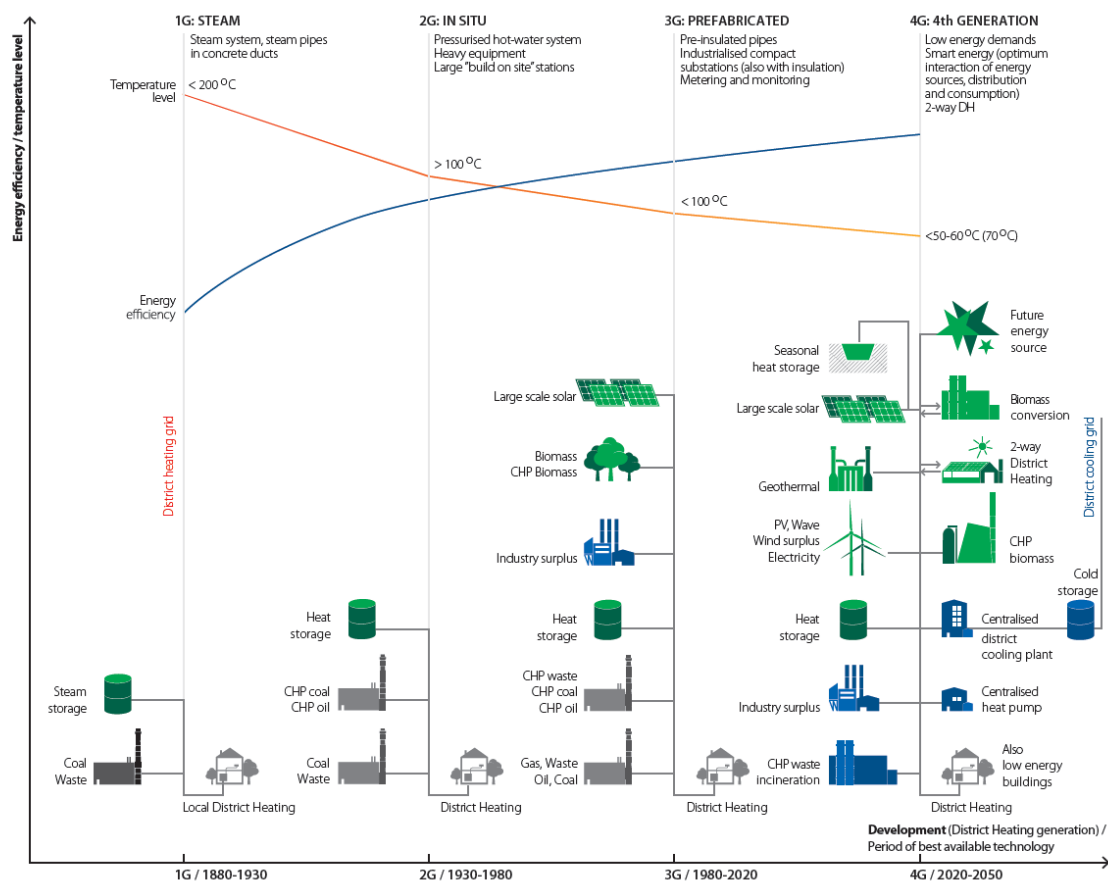

Figure 2.1

Evolution of the district heating systems (4DH 2017)

The development of large-scale district heating system and energy production units are not within the scope of ZEN. However, thermal networks will be an integral part of the energy system in the ZEN

pilots, and the concept of 4GDH can be transferred into smaller local networks, either isolated, or coupled to a larger grid. Stepwise integration of new or renovated neighbourhoods with thermal networks fitted to the 4GDH concept is also an important part in the transition to the next generation district heating system.

2.1 Main characteristics

(Lund, Werner et al. 2014) describes the following five challenges that the future 4GDH system needs to meet:

1. Ability to supply low-temperature district heating for space heating and domestic hot water (DHW) to existing buildings, energy-renovated existing buildings and new low-energy buildings.
2. Ability to distribute heat in networks with low grid losses
3. Ability to recycle heat from low-temperature sources and integrate renewable heat sources such as solar and geothermal heat.
4. Ability to be an integrated part of smart energy systems (i.e. integrated smart electricity, gas, fluid and thermal grids) including being an integrated part of 4th Generation District Cooling systems.
5. Ability to ensure suitable planning, cost and motivation structures in relation to the operation as well as to strategic investments related to the transformation into future sustainable energy systems.

This report focuses on the technical solutions in the network and connection to the buildings for approaching these challenges.

2.1.1 Temperature levels

From the evolvement of the district heating systems through the years and the definition of the 4GDH, one can see that the main parameter in focus is the temperature level. As seen in Figure 2.1, the temperature level of the district heating system has been steadily decreasing since the 1st generation steam based systems. Figure 2.2 show an example from Hafslund Varme on their supply temperature as function of outdoor temperature. At dimensioning conditions the supply temperature is 120 °C, in summer it varies between 85-75 °C (Hafslund Varme AS 2017).

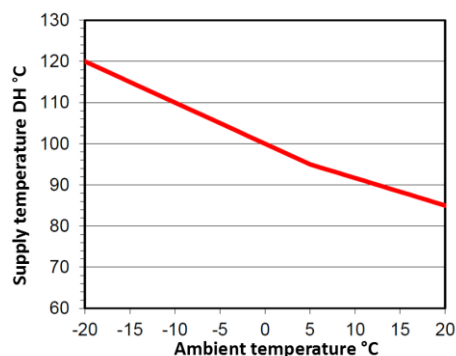

Figure 2.2:
Example of supply temperature in existing district heating system in Norway (Hafslund Varme AS 2017)

Benefits

Lower distribution temperatures have several advantages that makes it an integral part of the evolution.

Reduced heat losses

The heat loss from the district heating network in Norway has been steady at about 10-12 % the last 10 years (SSB 2017). Approximately two-thirds of the heat loss can be attributed to the supply pipe and one-third to the return pipe (Lauenburg 2016). With an improved building stock with lower heat demand, the relative heat loss in conventional district heating systems will increase (Olsen, Christiansen et al. 2014). This is due to an increase in the distribution pipe length per kWh consumption. Figure 2.3 shows how the relative heat loss increases with reduced linear heat density for district heating systems in Denmark. Similarly, the relative heat loss is higher during summer than during winter (Rosenberg 2010).

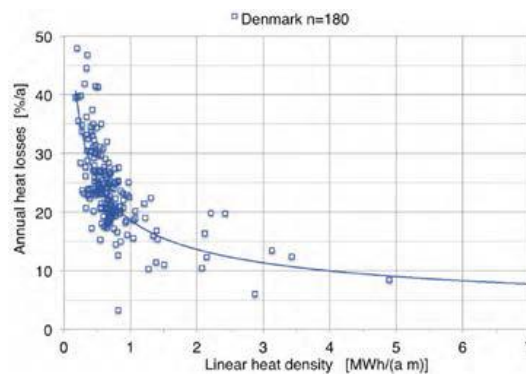

Figure 2.3:

Annual heat loss vs. linear heat density in Danish DH systems (Nord, Schmidt et al. 2016)

Heat loss from a distribution pipe (Q_{loss}) is mainly a function of temperature difference between the fluid (T_f) and the ground (T_g), and the insulation thickness.

$$Q_{loss} = UA(T_f - T_g)$$

The relationship between the temperature difference and the heat loss is approximately linear, which means a 50% reduction in temperature difference results in approximately 50% reduction in heat loss. Pipe size will also have an impact on the heat losses, and an increase in the pipe size will counter-effect part of the reduced heat loss. The relation between the temperature difference and pipe size is discussed in 2.3.1.

Improved efficiency of the production systems

Most renewable energy sources will benefit from a lower water temperature, both through increased production capacity and improved efficiency.

The efficiency of solar collectors is directly linked to the hot water temperature, as shown in Figure 2.4. The higher the temperature difference between the water and the ambient, the higher the heat loss and lower yield.

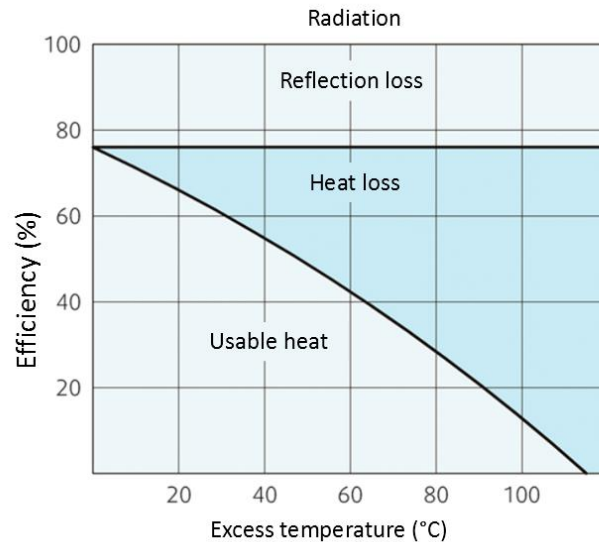

Figure 2.4: Connection between excess temperature (difference between water temperature and ambient temperature) and efficiency of solar collectors (Simonsen 2011).

Similar relationship can be seen for heat pumps in the connection between Coefficient of Performance (COP) and the temperature difference between the heat source and the heat supply (ΔT). Typically, the COP is reduced with 2-3 % for each °C increase in condensation temperature (supply temperature) or reduction in evaporation temperature (source temperature) (Stene 2009).

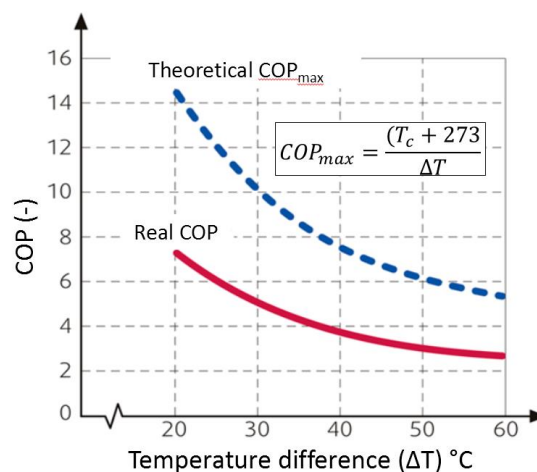

Figure 2.5: Connection between Coefficient of Performance (COP) and the temperature difference between the heat source and the heat supply (ΔT) (Stene 2009)

For combustion systems (boilers and CHP), low system return temperatures increases the possibility for flue gas condensation, and thereby increased exploitation of the heat and improved overall efficiency. This is especially relevant for waste incineration and biomass plants with high moisture content in the flue gasses (Olsen, Christiansen et al. 2014). For a boiler with flue gas condensation, a 5 °C reduction in return temperature increases the heat output with 1-5% without increasing the fuel consumption (Lauenburg 2016).

For CHP plants with two (or more) condensers in series, reduced return temperature increases the power-to-heat ratio. However, the potential is much higher if also the supply temperature can be reduced. A 5 °C reduction in supply temperature can increase the power-to-heat ratio with about 2 % (Johansson, Jonshagen et al. 2009).

Increased possibilities for heat recovery

Reduced temperature levels in the district heating network increases the possibility for use of secondary heat from industry or other sources such as ice-rinks and data centres, either by direct heat exchange or through upgrading with heat pumps.

Challenges with low temperatures

Lower supply temperatures also introduce several challenges. The most obvious challenge is the minimum demand temperature needed in the connected buildings. This is however mainly a challenge for existing buildings. There is currently ongoing ZEN work on opportunities and limits for applying low temperature district heating in existing buildings.

However, if the characteristics of the load are unchanged, reducing supply temperatures in existing district heating networks will also increase the return temperature (Lauenburg 2016). This is due to the increased flow rate needed to maintain the same mean temperature difference, and thereby supply the same amount of heat in the substations. The reduced temperature difference results in reduced capacity in the district heating network, and if the flow limit is reached, the end users might not be supplied with the necessary heat. Measures in substations and buildings are therefore necessary before the supply temperature can be reduced.

For new developments, with low energy buildings designed for low supply temperatures, it is important to focus on measures to reduce return temperatures, to increase temperature differences, and shave peak loads to counteract larger pipe sizes and higher infrastructure investment cost. Substation designs for low return temperatures are discussed in section 2.3.3.

Legionella

One of the main obstacles to reduce the DH temperature below 70 °C is the risk of legionella growth in the domestic hot water (DHW) systems. Legionella is a bacterium that can cause serious, sometimes lethal, illness if inhaled in aerosols. The growth or decay of legionella is strongly linked to the water temperature, as shown in Figure 2.6. The Legionella bacteria spreads through breathing aerosols that are contaminated by the bacteria (Pettersen 2010). Aerosols can e.g. be generated by cooling towers or shower heads.

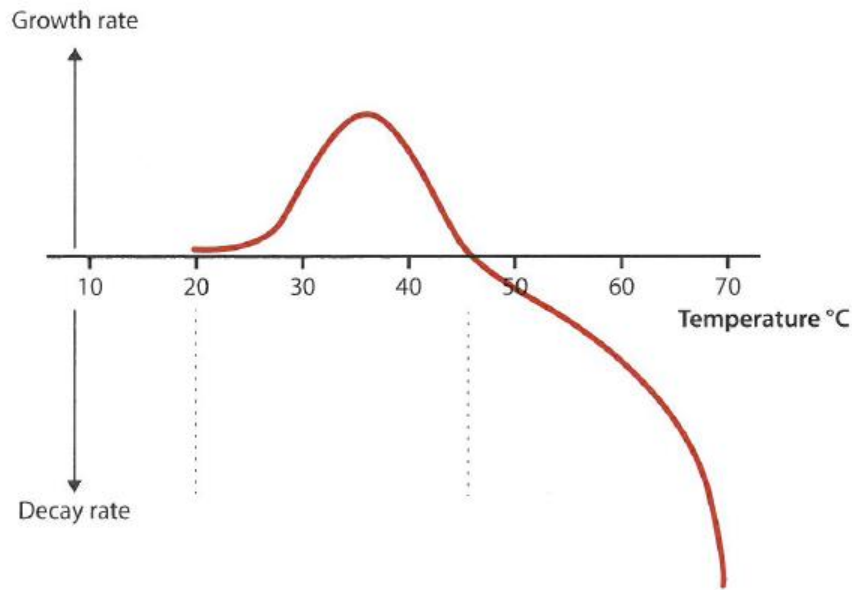

Figure 2.6:
Legionella growth/decay as function of temperature (Frederiksen and Werner 2013)

Norwegian Regulations on technical requirements for building works (TEK) does not give concrete regulations on temperatures in DHW system, but states that water installations should be designed in a way that secures good health. A recommendation of minimum 65 °C in DHW circulation systems is given. (Pettersen 2010) recommends that the DHW temperature should reach 60 °C at the tapping point within maximum 1 minute, and that return temperature of circulation circuits should not be below 60 °C. Similar regulations exist in Sweden and Denmark, but minimum temperature recommendations are set to 50 °C for the distribution system and 60 °C for hot water storage tanks (SSI 2000, Boverket 2011).

In many publications and examples with low temperature district heating (LTDH) systems, a maximum system volume of DHW from the heat source to the tapping points is mentioned as a method to reduce or remove the risk of legionella growth. This number seems to originate from the DVGW-worksheet from Germany (DVGW 2004). This code of practice divides systems into small and large. Small systems are defined as single or two-family houses or systems with hot water heaters smaller than 400 litres and less than 3 litres in the piping between the production unit and the tapping points (circulation piping is not included). The worksheets state that for small installations measures are not required, but recommended.

2.2 Implementing low temperature district heating

The transition to 4GDH will be gradual and can be done in several different ways. (Olsen, Christiansen et al. 2014) discusses four different development scenarios (Figure 2.7).

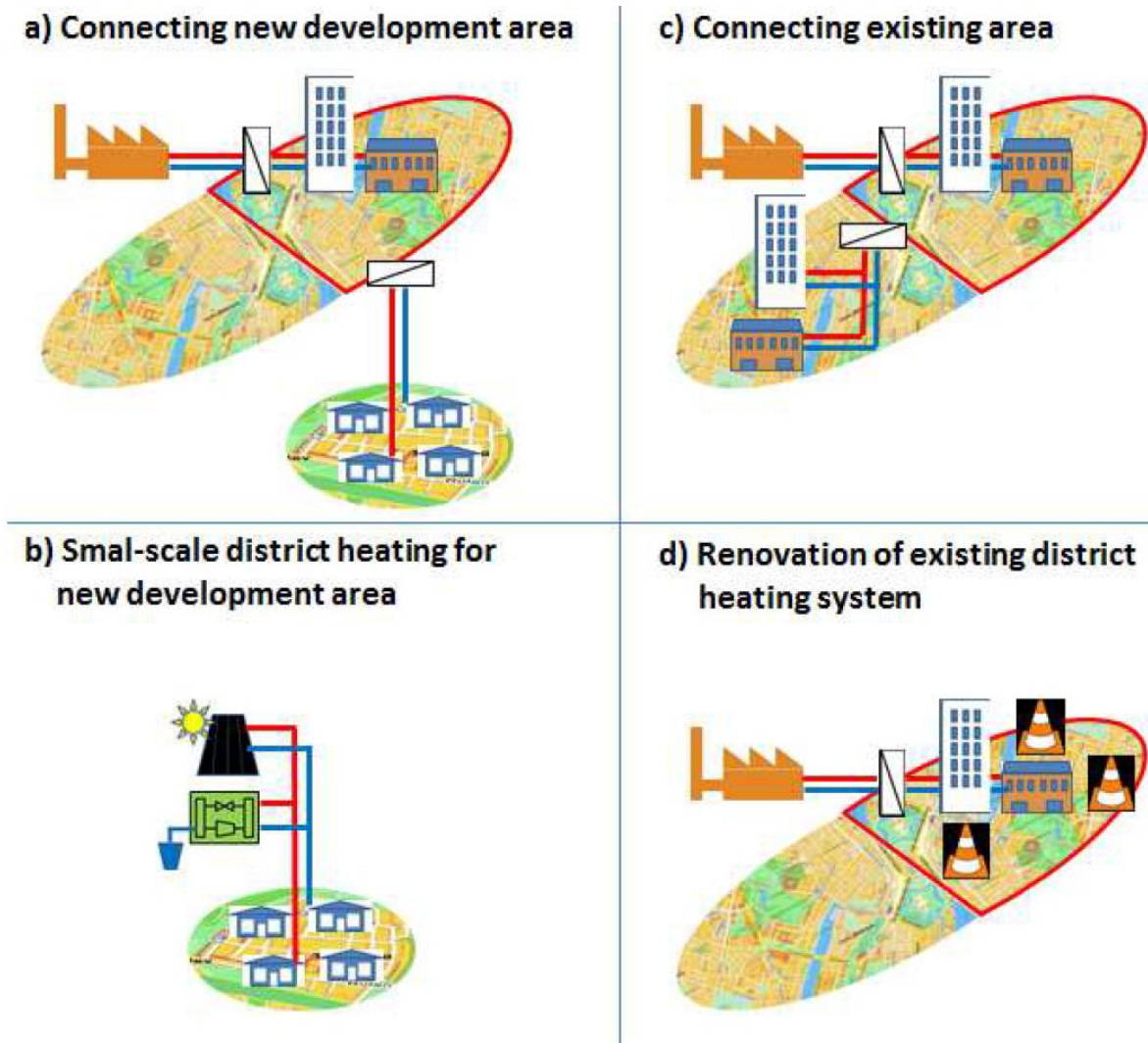

Figure 2.7:
Development scenarios for low temperature district heating (Olsen, Christiansen et al. 2014).

For a new area that is not connected to district heating (b), a low temperature network with dedicated heat source can be installed. When connecting to an older generation district heating system, a solution that benefits the total network should be applied. When connecting a new development area (a) or establishing a new low temperature network in an existing area connected to an existing DH network (c), the temperature level can be lowered by either a shunt connection (Figure 2.10a) or heat exchanging, or in some cases the new areas can be connected to the return line of the existing network (Olsen, Christiansen et al. 2014, Lauenburg 2016). More details on such connections are discussed in section 2.3.2. In areas with existing DH networks, renovated and new buildings should be prepared for low temperature networks in the future, both in the design of the building heating system and the substation (Olsen, Christiansen et al. 2014).

2.3 Technical solutions

In this section, some technical solutions and recommendations are discussed.

2.3.1 Piping and insulation

As mentioned above, one of the main challenges for next generation district heating is to reduce heat losses. At the same time, reduced temperatures will result in reduced temperature differences, and thereby increased flow for the same thermal capacity. This also means reduced heating capacity for a given pipe dimension. Figure 2.8 shows typical pipe capacities as function of pipe dimension and temperature difference. The capacity increases with a factor of about 1,5-2 per pipe size (DN). This means that halving the temperature difference results in the need to step up one pipe dimension with the same capacity.

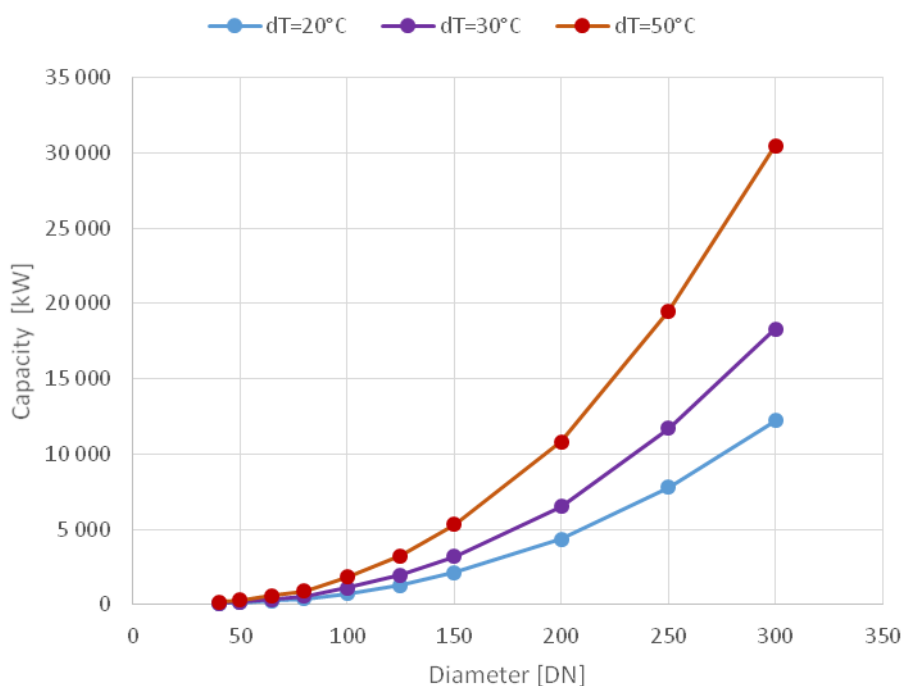

Figure 2.8:
District heating pipe dimension capacity at different temperature differences. Derived from (Rosenberg 2010).

The cost for DH infrastructure is closely related to pipe dimension. Figure 2.9 shows the cost in NOK/m ditch (kr/m grøft) for different pipe diameters. The costs are divided in pipe and components (rørmateriell), piping labour (rørarbeid), ditch (grøftarbeid), project design/management (prosj/byggeledelse), addition for asphalt (påslag asphalt) and addition for work in central areas (påslag sentrum).

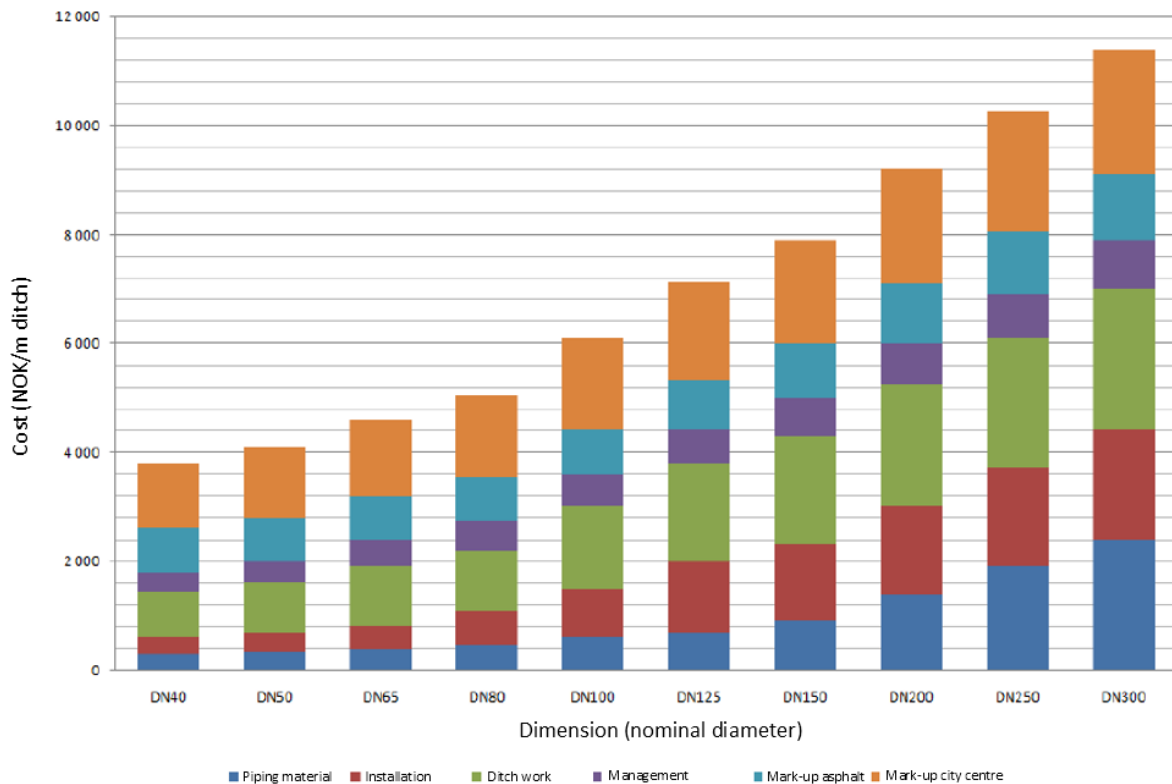

Figure 2.9:
Cost for district heating infrastructure (spring 2010) (Rosenberg 2010).

For smaller dimensions (up to DN200), it is possible to utilize twin piping. Twin-pipes consist of two pipes (supply and return) in the same casing. This configuration has a factor of 2 lower heat loss compared to two single pipes (Lund, Werner et al. 2014). The cost of twin-pipes varies largely with dimensions, but for smaller diameters, a single twin pipe is cheaper than two single pipes (Rosenberg 2010).

The use of low temperature district heating also enables for use of flexible piping. Flexible piping has the potential for simpler installation and lower cost (Rosenberg 2010, Frederiksen and Werner 2013).

2.3.2 Connections between existing DH system and new LTDH network

As mentioned in section 2.2, there are several concepts for how a new area, which is prepared for low temperature district heating, can be connected to a traditional DH network. Two options for direct connection can be seen in Figure 2.10 (both solutions could also be designed with heat exchangers, to create a pressure barrier). a) Shows a traditional three-way shunt connection, which will lower the supply temperature by mixing in the return from the LTDH network. This connection will yield a low return temperature into the existing DH network, and therefore lower the total return temperature by mixing, but the effect will be dependent on the demand ratio between the two circuits. b) shows the three-way connection that utilizes the return line from the DH network to reduce the supply temperature. If the flow and temperature in the return line is high enough, theoretically up to 100% of the energy can be transferred from the return. This would mean that the district heating company would not need to increase the capacity of the network (the demand from the heat production unit would still increase). (Flores, Corre et al. 2014) has studied the possibility of such integration, and

found that 20-50% of the energy can be supplied from the return line of the main DH network in a case with a LTDH network with supply temperature of 60 °C. The results will largely depend on the temperature level and flow rate of both the main DH network and the LTDH network.

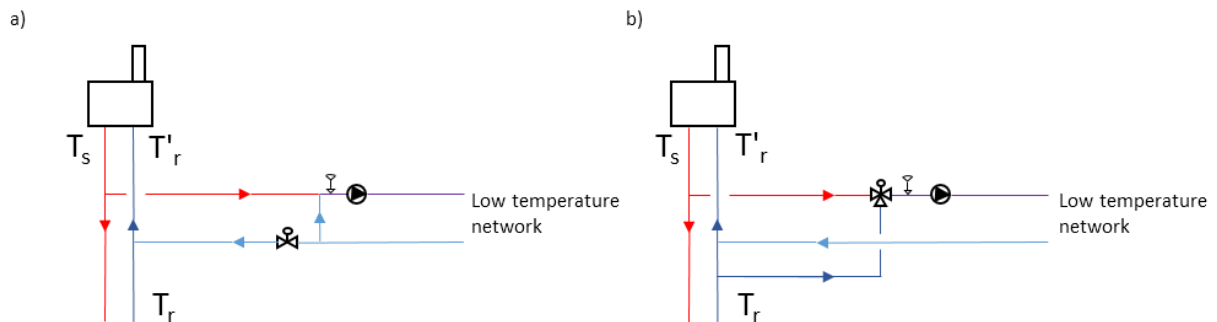

Figure 2.10:

Shunt connections between a LTDH network and a traditional DH network. Adopted from (Olsen, Christiansen et al. 2014).

2.3.3 Substations and consumer connection

The most common substation designs in the Nordic countries are the parallel and 2-stage connection designs shown in Figure 2.11. The 2-stage connection has been very popular in Sweden, and leads to somewhat lower DH return temperatures compared to the parallel connection. The main principle is to utilize the low temperature of the domestic cold water in a pre-heater (PH) to reduce the return temperature, before the DHW is heated further in the after-heater (AH). However, in the recent years the parallel connection has become predominant due to its simplicity and lower cost (Frederiksen and Werner 2013).

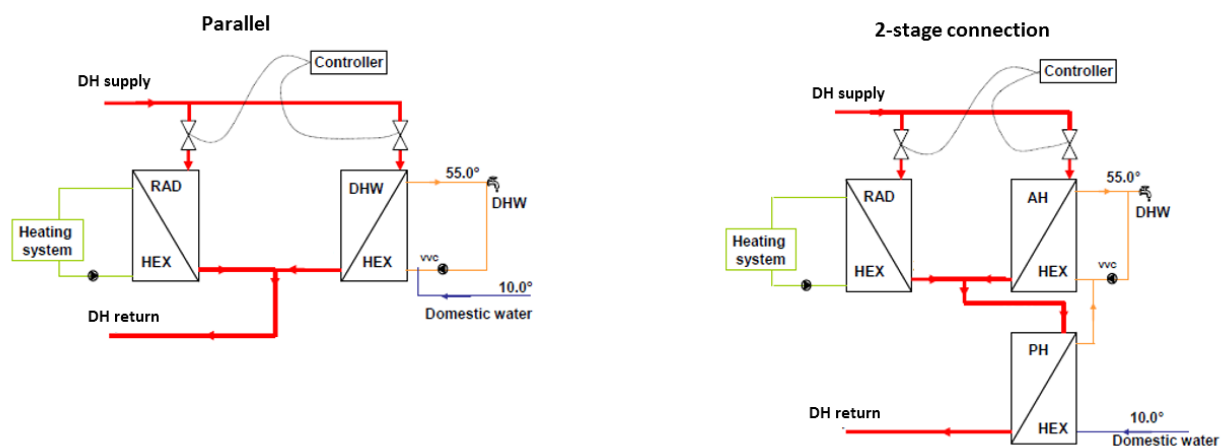

Figure 2.11:

Traditional substation design. Derived from (Johansson, lauenburg et al. 2009)

(Johansson, lauenburg et al. 2009) shows that it is possible to reduce the return temperature by several degrees, with more sophisticated and complex substation designs, such as the "Russian" 3-stage connection shown in Figure 2.12.

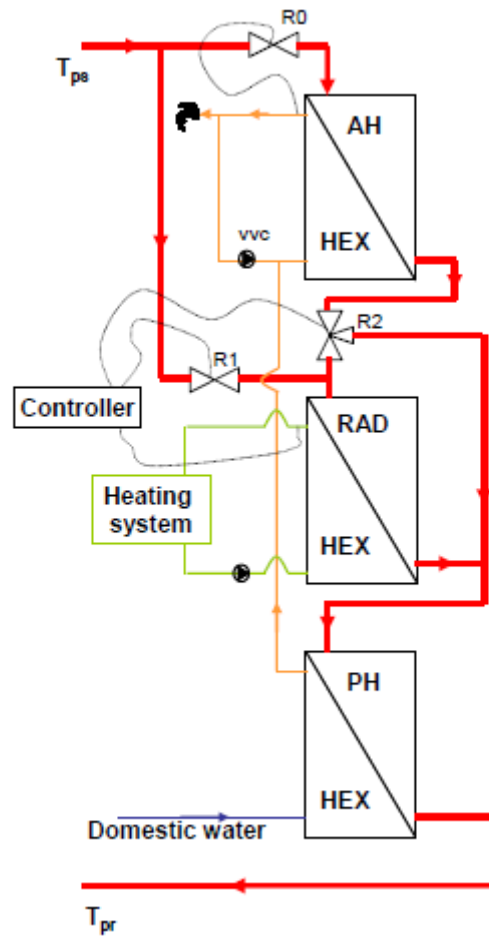

Figure 2.12
"Russian" 3-stage DH connection (Johansson, lauenburg et al. 2009)

However, the main cause of high return temperatures in DH networks are related to substation malfunctions (Lauenburg 2016). (Lindkvist and Walletun 2005) found that the substation connection scheme (parallel or 2-stage) is of secondary importance. However, it is of high importance for the functioning of the primary and secondary net that is adjusted to the secondary net. This indicates that more effort should be put in dimensioning and designing well functioning substations and secondary networks, than inventing advanced connection schemes.

All the substations mentioned above are of the instantaneous heat exchanger unit (IHEU) type. As mentioned earlier, one of the challenges for 4GDH is to reduce the peak loads. One option for this is to install storage capacity for domestic hot water, co-located with the substation. Storage of DHW at low temperatures would increase the risk of Legionella growth. Therefore, storage on the primary side of the DHW heat exchanger has been studied. An example of such substation is shown in Figure 2.13. Alternatively, this can be solved with a coil for DHW production inside the storage tank, which eliminated the need for the extra pump.

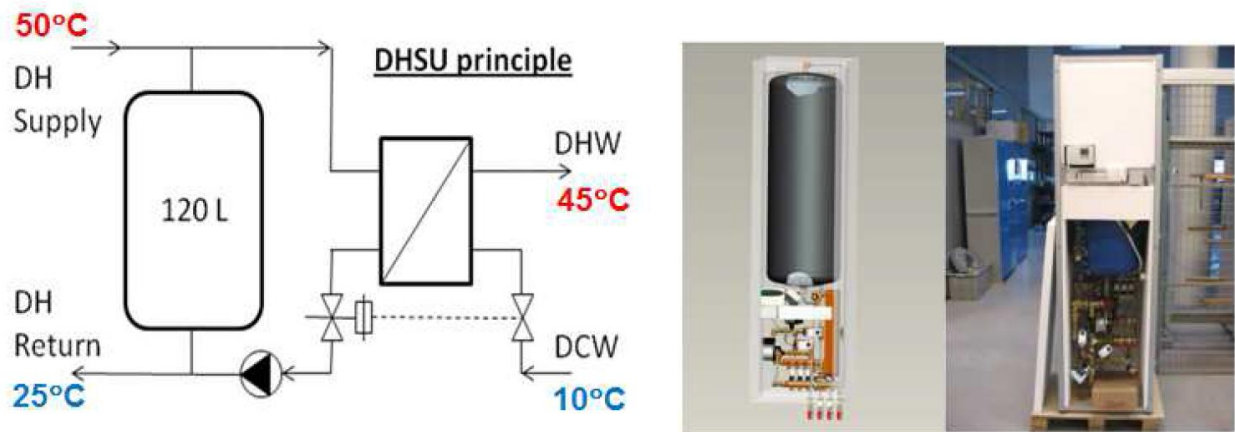

Figure 2.13
District heating storage unit (DHSU) (Olsen, Christiansen et al. 2014).

The traditional solution for apartment blocks in Scandinavia is a common substation with distribution of hot water for heating and DHW including circulation, to the apartments. Both to reduce heat losses and to reduce the risk of legionella growth, it is proposed to install individual substations in each apartment (flat stations). The concept of flat stations reduces the piping cost to each apartment by reducing the number of pipes in the main distribution system, from five (Heating supply (HS) and return (HR), hot water (DHW), cold water (DCW) and hot water circulation (HWC)), to three pipes (HS, HR, DCW). On the other hand, it increases the cost of the apartment due to multiple substations. Such layouts have gained some popularity in Germany, where it is mandatory to measure heat consumption for each flat. In Scandinavia, it is generally viewed as rather costly (Frederiksen and Werner 2013). The use of flat stations can enable systems with less than 3 litre volume in the hot water piping, and might therefore be a more attractive solution for LTDH systems, due to reduced legionella risk.

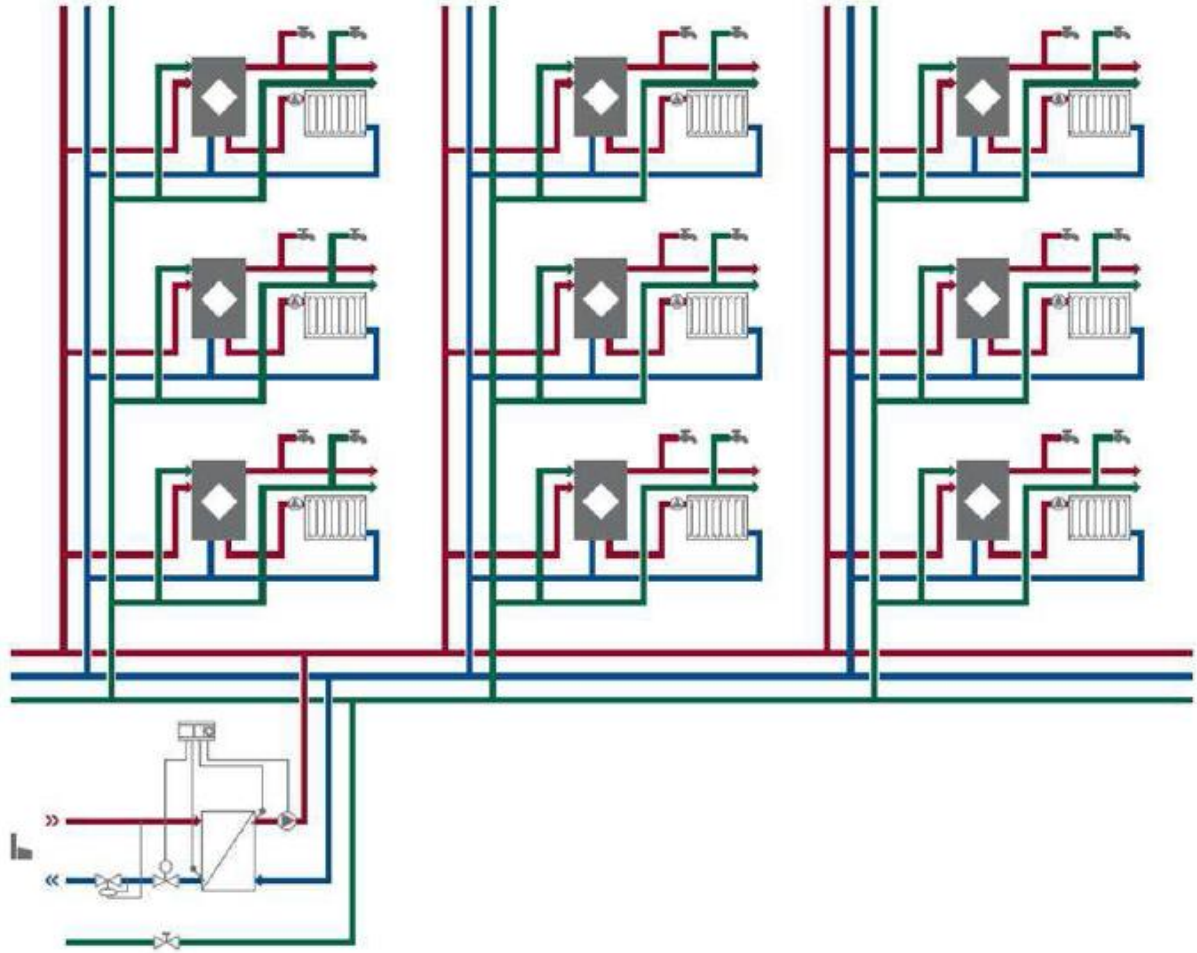
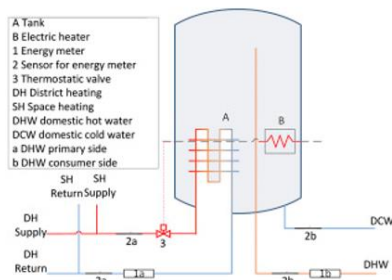

Figure 2.14:
Flat station layout in multi-storey apartment block (Olsen, Christiansen et al. 2014).

Reducing the supply temperature even further to below 50 °C is often referred to as ultra-low temperature district heating (ULTDH). For these systems, the supply temperature is normally not high enough to reach the comfort/sanitary demands for DHW, in addition to the increased possibility for legionella growth. This means that supplementary heat devices are necessary. (Yang, Li et al. 2016) studied several different supplementary heat solutions, including electric water heaters, micro heat pumps and instantaneous electric heaters. Four of the evaluated solutions are shown in Figure 2.15.

The study was based on a combination of measurements from existing residential houses in Denmark, and modelling of the substations to compare them at standard conditions. The main results from the study were that the best energy performance is reached by instantaneous heat supply, due to the heat losses from the storage tanks. The heat pump solution was evaluated as the poorest solution, mainly due to large heat losses from the compressor. It was assumed a constant heat loss of 140 W, which accumulated to over 50 % of the heat demand for DHW. This assumption seems strange, with a heat pump with maximum power of 250W. A challenge with the concept of instantaneous electrical heating is the high peak power demand needed. It will therefore be a trade-off between the flexibility of a storage tank and the accompanying heat loss (similar to the DH only solutions discussed above).

a) Immersion water heater with electric coil



b) Electric water heater on primary side

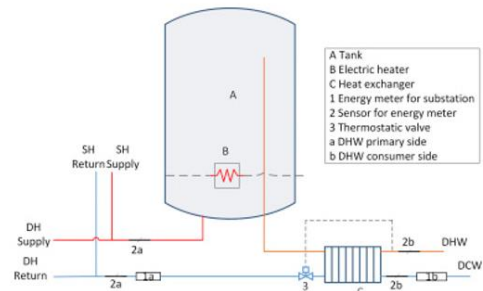

c) Heat pump with storage tank

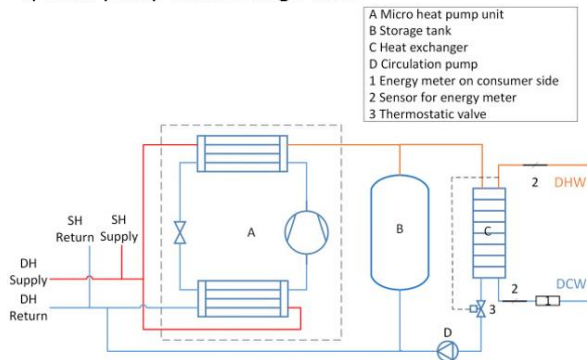

d) Instantaneous electric heater

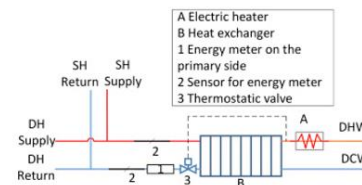

Figure 2.15:

Options for supplementary heating in ULTDH systems (Yang, Li et al. 2016)

Most literature only discusses LTDH and ULTDH solutions for residential buildings. For non-residential buildings, such as offices, nursing homes, supermarkets and hotels, low temperature solutions with low volumes in the DHW system might not be feasible. In these cases, similar boosting systems as discussed above might be a reasonable solution with DH temperatures below 60 °C.

2.4 Examples of low temperature projects

Below, some examples of LTDH demonstration districts are discussed.

2.4.1 Lystrup, Denmark (Olsen, Christiansen et al. 2014)

In Lystrup, an area outside Ålborg in Denmark, a demonstration site with 40 terraced low-energy houses and a communal building is situated. Key data for the area is shown in

Table 2.1.

Table 2.1: Lystrup, key data

Key Data	
Heat source	District heating – shunted connection (Figure 2.10a)
Total Heated Area	4 115 m ²
Total delivered heat	280 MWh/year
Distribution heat loss	50 MWh/year (18 %)
Measured	
Supply/return temperatures design	55/30 °C
Supply/return temperatures measured	52/34 °C
Piping	Twin-pipes series 2 with diffusion barrier
Consumer substations	Individual substations: 11 DHSU, rest IHEU
Heating solution	Radiators and bathroom floor heating

In the design phase, calculations showed that the heat losses in the distribution pipes with a conventional district heating system would be approximately 4 times higher than with a LTDH concept (200 MWh instead of 50 MWh).

The use of DHSU units with 120 l storage tanks made it possible to reduce the substation capacity with 3 kW and the distribution pipes accordingly. Results showed that the heat loss from the areas with DHSU substations were less than for areas with IHEU substations, but the total heat loss including losses from the storage tanks were larger. The use of DHSU was still found useful in areas with capacity limitations due to the flexibility and reduced peak loads.

Each flat/house has its own substation, and effort was put in keeping the total DHW volume below 3 liters to reduce legionella risk.

2.4.2 Sønderby, Denmark(Olsen, Christiansen et al. 2014)

In Sønderby, an area outside Copenhagen in Denmark, a demonstration site with 75 detached brick houses is situated. The houses were built in the period 1997-1998. The original DH network in the area was in a bad condition with high heat losses, and the main focus for the project was to lower distribution heat losses by reducing supply temperature, pipe dimensions and length.

Key data for the area is shown in

Table 2.1.

Table 2.2: Sønderby, key data

Key Data	
Heat source	District heating – return connection (Figure 2.10b)
Total Heated Area	11 230 m ²
Total delivered heat	1227.7 MWh/year (2012)
Distribution heat loss	176 MWh/year (14 %)
Measured	
Supply/return temperatures design	55-52/30-27 °C
Supply/return temperatures measured	55/40 °C
Piping	Twin-pipes with diffusion barrier. Steel pipes series 2 for main distribution network and AluPex
Consumer substations	IHEU (Danfoss Redan Akvalux II VX)
Heating solution	Floor heating

The local area heating network is connected to the existing DH network with a 3-way connection similar to that shown in Figure 2.10.

Legionella risk was reduced by individual substations and keeping the DHW volume below 3 liters.

Measurements show that 81% of the heat to the LTDH network is supplied via the DH return line. During the first years of operation, the return temperatures have been somewhat higher than the design. This is mainly due to some malfunctioning substations.

2.4.3 Østre Hageby, Stavanger (Line 2013)

Østre Hageby is a residential building area in Stavanger, with 66 new apartments with total area of 6800 m². The energy system consists of a ground source heat pump system with nine, 200 m deep, boreholes. Since there is no cooling demand, a dry cooler is used to restore the heat balance during summer in the borehole heat exchanger during summer. This ensures that the boreholes do not freeze, and reduces the necessary number of boreholes. The system is designed with a supply temperature of 55 °C, and flat stations with local DHW production to reduce legionella risk.

2.5 Decentralized and distributed sources and building interaction

Traditionally, district heating systems have been characterised by central heat supply and one-way distribution (Lennermo, Lauenburg et al. 2014). An important part of the 4GDH concept is the ability to utilize local renewable sources and available surplus heat. (Nord, Schmidt et al. 2016) distinguishes between decentralized and distributed energy sources. Decentralized sources are heat sources that are connected to the DH network at different geographical locations, but are controlled by a central actor (DH company). Distributed energy sources is when external buildings/actors supply heat into the district heating network (e.g. industrial waste heat or private solar collector systems).

2.5.1 Prosumers

The prosumer concept already exists for electricity, allowing costumers that produce more power than they consume to sell their power to the market. For local electricity production, such as from solar

cells, there is a simplified prosumer arrangement for end users with consumption and production behind connection point, as long as certain conditions are fulfilled.

As of today, the Energy Act (*Energiloven*) also provides a framework for heat-prosumers in a DH network. § 5-6 describe that the concessionaire has a duty to negotiate with a third party which wants to deliver heat to the district heating system. If the parties do not agree, the concessionaire needs to justify its refusal.

2.5.2 Connection principles

The local heat source can be integrated into the DH network in three different ways: from the return pipe to the supply pipe (RS), directly on the return (RR), or directly on the supply (SS) (Ben Hassine and Eicker 2013). The RS connection is the solution with the highest potential and the most common one (Lennermo, Lauenburg et al. 2014, Dalenbäck 2015). The RR connection is attractive for available surplus heat sources with temperatures below the supply temperature of the DH network. One of the main drawbacks with this connection is that it will increase the return temperature to the main plant. Depending on the heat production methods in the central plants, the efficiency and capacity can be reduced. Alternatively, the heat can be upgraded to a higher temperature level with a heat pump, and connected with the RS scheme. The SS connection is mainly useful for boosting the temperature locally for distant costumers and normally not suited for local renewable sources, as these benefit from low temperatures.

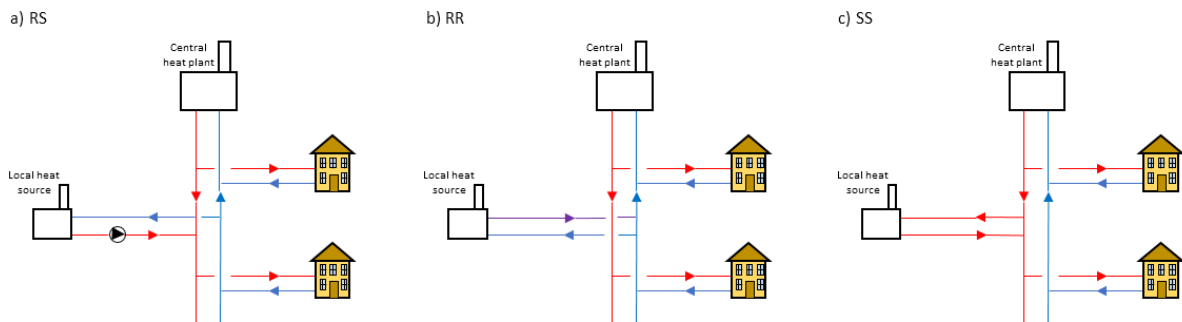

Figure 2.16
Connection principles for local heat sources in DH network. Reproduced from (Ben Hassine and Eicker 2013)

Figure 2.16 shows integration principles for decentralized energy plants in the DH network. Figure 2.17 shows a possible solution for prosumer connections with connection of the heat source to the primary side of the DH network. When the prosumer is producing more than its consumption, water is drawn from the DH return line, heated, and pushed back into the supply pipe (RS). A control system, controlling pumps and valves, is necessary to make sure the correct temperature and pressure is delivered into the DH network. Several different connection types (primary, secondary or mix) and control strategies (temperature or flow) are discussed in (Lennermo, Lauenburg et al. 2016). One of the main challenges for the feed-in substations is to overcome the dynamic pressure difference between the supply and return line. Studies have shown that there are challenges with fluctuation pressures when controlling the flow in "feed-in" substations (Hassine and Eicker 2014, Lennermo, Lauenburg et al. 2014).

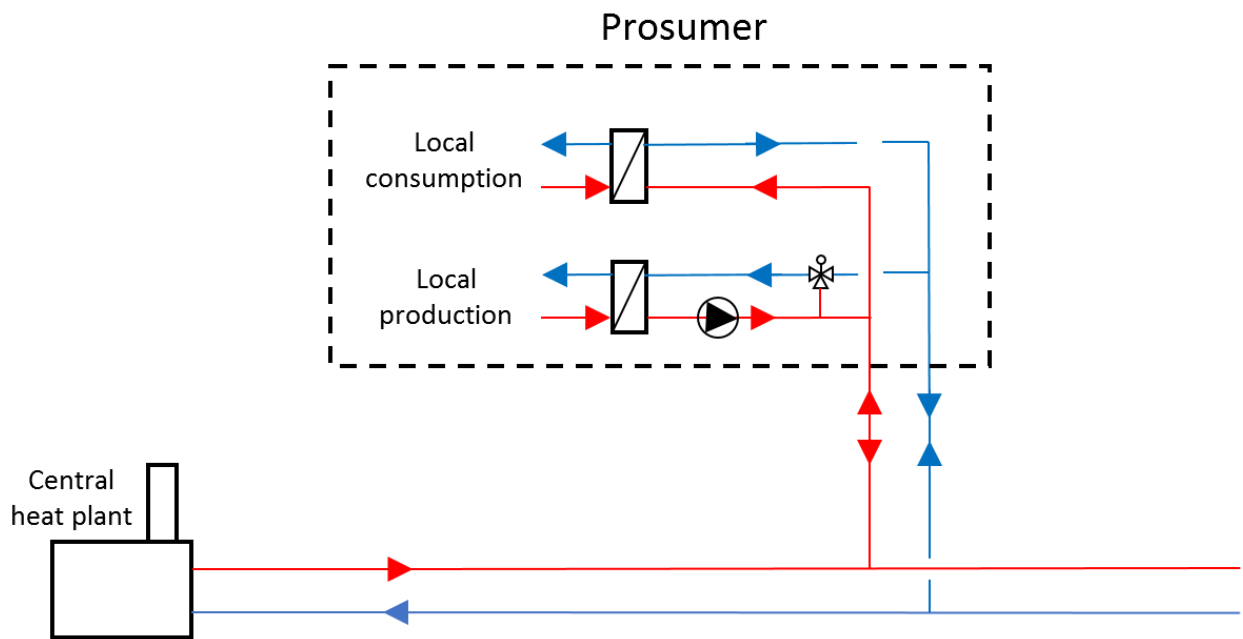

Figure 2.17:
Principle prosumer connection

2.5.3 Examples

Distributed solar collectors in Sweden

In Sweden, about 30 distributed solar collector systems that are connected to the primary side of the DH network (similar to Figure 2.17) have been installed on buildings since early 2000s. (Dalenbäck, Lennermo et al. 2013) has studied 22 of these systems and how they perform. The yearly specific delivery to the district heating network is shown in Figure 2.18. The yield is lower than expected for solar collectors compared to the solar irradiation. This is mainly due to not optimal installation of the collectors themselves, but partly also due to control issues in the connection with the DH network. High return temperatures are also a challenge for the collectors.

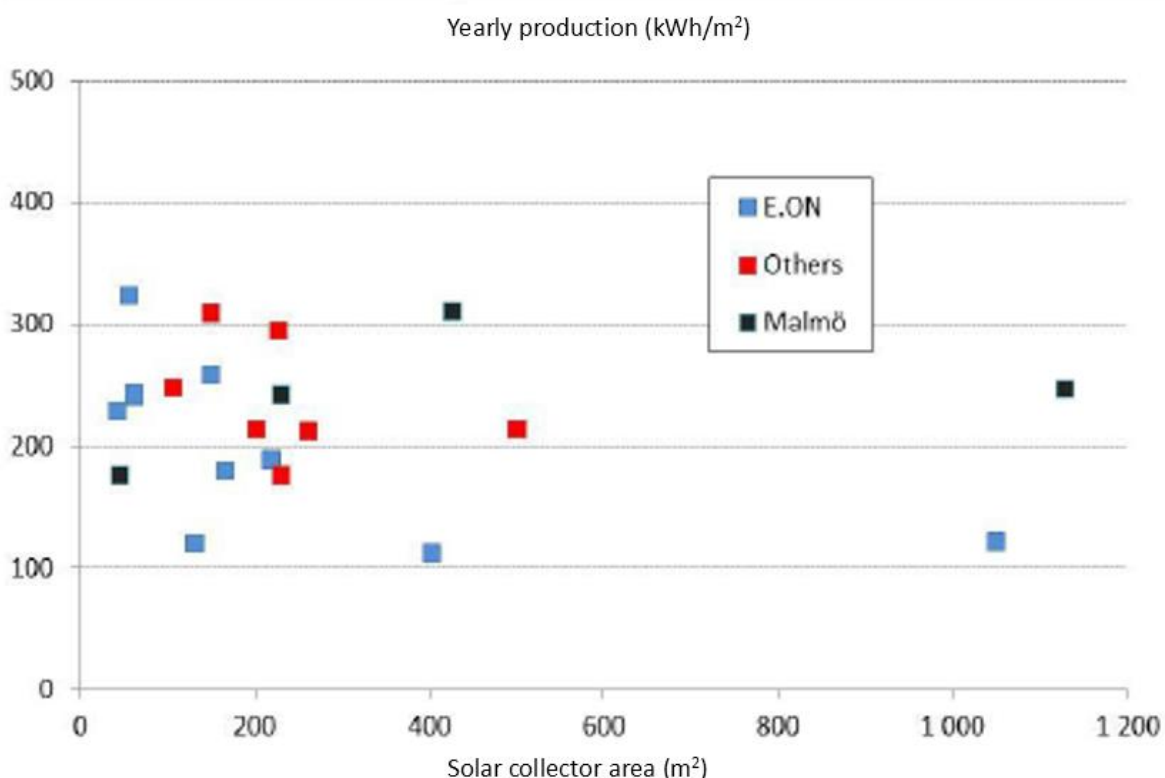

Figure 2.18:

Yearly heat delivery from distributed solar collector to district heating network (Dalenbäck, Lennermo et al. 2013)

Figure 2.18 shows the different installations, colour coded to indicate owner. Most of the systems are owned and operated by the DH company E.ON and are installed in Malmö. In this case the complete system is maintained and controlled by the DH company. In other cases, either building owners, the municipality or an energy service company (ESCO) owns the system. In this case they must have an agreement with the DH company to sell the heat (Dalenbäck 2015).

Open District Heating ("Öppen Fjärrvärme") Stockholm (Fortum 2017)

Fortum has opened up their DHC network in Stockholm to third party heat delivery. Any company with surplus heat or cold that are located close to the DHC network can sell energy to the network at market price conditions. The project was started in 2013 and officially launched in 2014. The model was developed by Fortum and Stockholm City together with several pilot partners (data centres, grocery store and local heating network with biomass boiler).

There are two main price models, a spot price model and a call-off order model. The spot price is typically used for costumers/producers with intermittent heat surplus. They can deliver their desired amount of heat, at spot market prices. The prices are calculated with a model based on estimated outdoor temperature and estimated consumption. Spot prices are published one day in advance together with temperature demand. Heat suppliers can deliver at three temperature levels: prime (supply temperature), mixture (a little lower than supply temperature) and return (1°C higher than the return temperature). The different temperature levels have different prices.

Heat suppliers with a more constant level of heat available (e.g. data centres) can sign call-off contracts. They deliver heat when Fortum asks for it, at more stable prices.

The prices also vary between predefined districts.

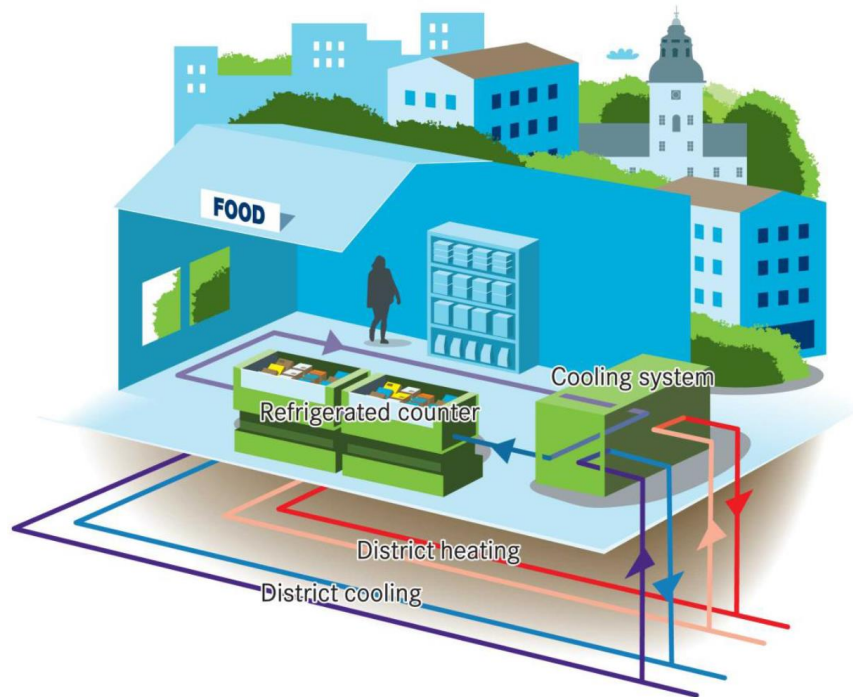

Figure 2.19:
Principle connection of grocery store to Open District Heating (Fortum 2017)

Stockholm City and Fortum has used the concept to attract new companies with computer centres to Stockholm, by offering to buy the surplus heat from the cooling systems. In this way they expand the benefits from only increased energy efficiency into also increased attractiveness for companies to locate themselves in Stockholm.

Trondheim, Campus Gløshaugen (Stene 2015)

Another example is from one of the ZEN pilots, the "Knowledge-axis" Trondheim. In 2014 NTNU Campus Gløshaugen installed a new heat pump system for cooling of the data centre. Campus Gløshaugen is connected to the city DH network. Until 2012 all the buildings were directly connected to the primary side of the DH network. Due to the high temperatures of the DH network, it was decided to separate the campus into a sub network. This allowed NTNU to operate the system with a lower supply temperature, which allowed for heat recovery.

The new heat pumps are NH_3 heat pumps able to deliver up to 80 °C. The supply temperature in the local heating network is 95 °C, so the heat recovery was connected to the return line (RR-connection). Figure 2.20 shows the power duration curves for the heat demand (Varmebehov), cooling demand (kjølebehov) and available heat from the data centre cooling (overskuddsvarme). Also the design supply and return temperatures are shown. The available heat has an approximate match with the

minimum heat demand, so that most of the heat can be recovered. The system is not designed to deliver heat back to the DH network.

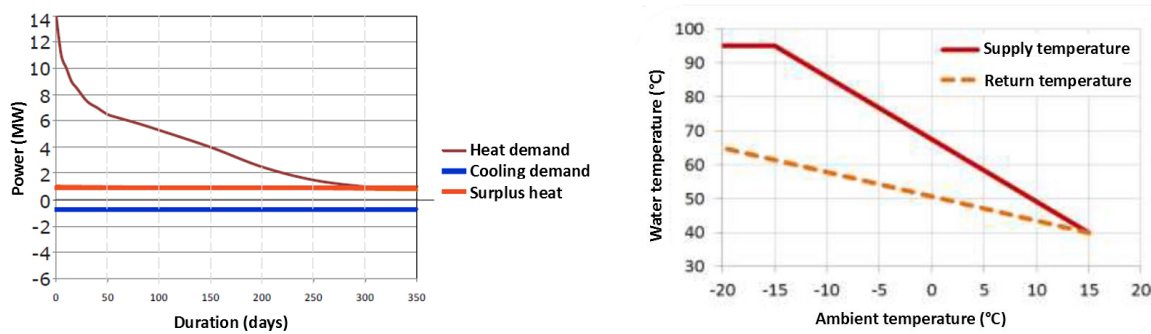

Figure 2.20:

Power-duration curve and temperature levels for Campus Gløshaugen (Stene 2015)

Estimated performance factor (COP) for combined heating and cooling is 5, giving 3 kWh of heating and 2 kWh of cooling per kWh of electricity to the compressor.

3 Ground source heat pump systems and seasonal storage

Geothermal heat, and especially ground source heat pump (GSHP) systems, have become steadily more popular in the Nordic countries. By the end of 2015, the total capacity in Europe was more than 20 GW_{th}, distributed in over 1,7 million installations (EGEC 2017).

3.1 Shallow geothermal heat with heat pumps

Shallow geothermal heat is mainly stored solar energy, with a small contribution from radioactive decomposition of elements in the bedrock (Ramstad 2011). Normally the boreholes are 50-350 m deep (Midttømme, Ramstad et al. 2015). At these depths, the bedrock temperature is approximately equal to the seasonal average temperature above ground.

GSHP systems can be an open system, where ground water is pumped up from an extraction well, utilized for heating or cooling, and then pumped down in an injection well. More common is the closed loop system with a circulation fluid exchanging heat with the ground in a borehole heat exchanger. More than 90% of geothermal energy installations in Norway are closed loop borehole heat exchangers. (Midttømme, Ramstad et al. 2015). (NGU 2017) has made an overview of larger geothermal borehole fields in Norway, showing 364 borehole fields with 10 or more boreholes registered per April 2017.

3.1.1 Components

A standard GSHP system consist of a borehole heat exchanger, collector and collector fluid distribution pipes, heat pump(s), and a heating circuit. When needed a cooling circuit is also connected. A principle scheme is shown in Figure 3.1.

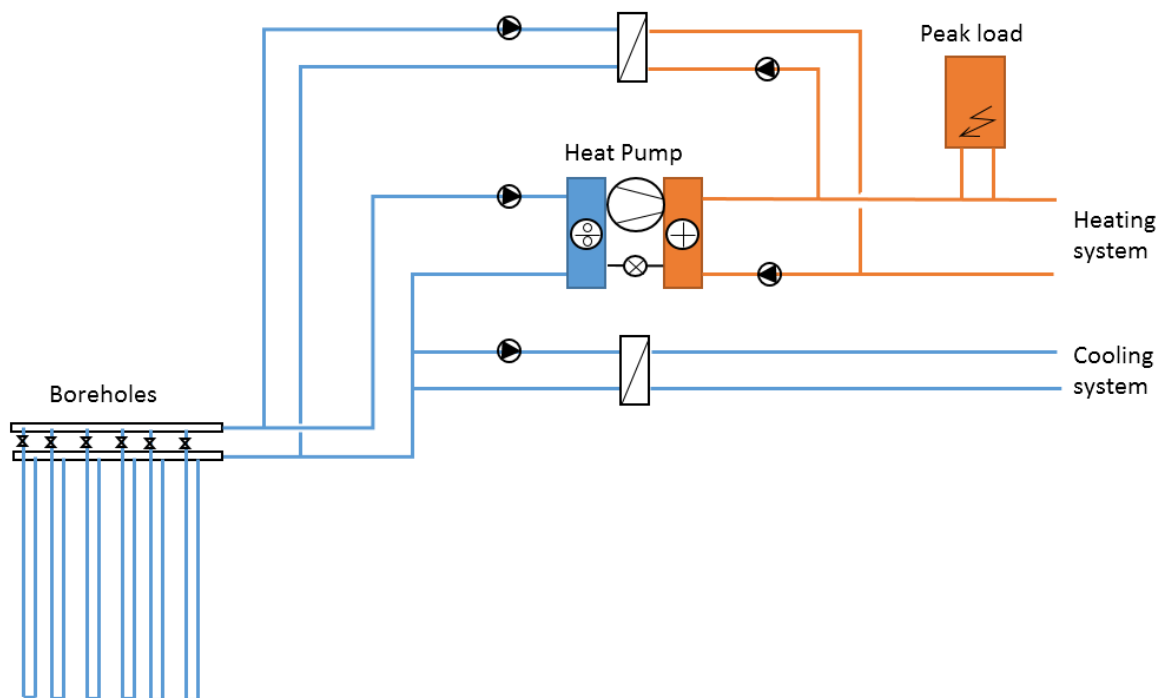

Figure 3.1: Principal GSHP system.

The borehole heat exchangers are drilled through the superficial deposit layer and into the bedrock, with a steel casing. The casing is mounted into the bedrock and sealed with cement.

Typically, the boreholes have a diameter of 115mm (139 mm casing) and single U-tube $\varnothing 40 \times 2,4$ mm collectors. The active borehole length is normally defined from the ground water level. **A principle drawing of a borehole heat exchanger is shown in Figure 3.2.**

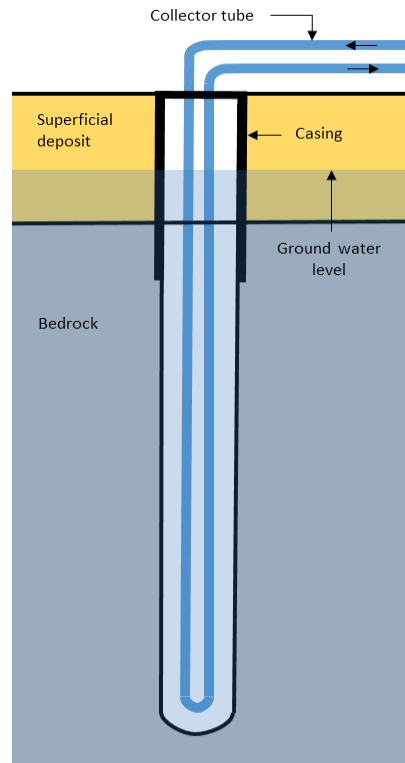

Figure 3.2:
Principle drawing of borehole heat exchanger

The collector pipes

Most of the work on improving the performance of borehole heat exchangers has been on the collector piping. The main goal of improving the performance of the collectors is to reduce the thermal resistance in the borehole, and thereby reduce the temperature difference between the fluid and the ground. As discussed in section 2.1.1, 1 °C change in evaporation temperature may represent a change in COP of 2-3% for a heat pump.

Some measures to increase collector efficiency have been implemented commercially: spacers between the two collector pipes, to make sure they are separated and located closer to the wall, and helical grooves inside the collector pipe (turbocollector). The collector efficiency is normally defined by the borehole thermal resistance. This is the thermal resistance between the collector fluid and the borehole wall. (Acuña 2010) did numerical and experimental work on the effect of these concepts. In the experiments, no improvement was found in the use of 13mm spacers between the collectors. However, numerical simulations indicated that 38mm spacers could have a significant impact. The experiments showed that the use of grooves could have an effect, especially for small flow rates (approximately 10% reduction in borehole resistance). There are, however, large uncertainties in such experiments, e.g. how the collector is positioned in the borehole, that influences the results.

Another concept that was studied by (Acuña 2013), is a pipe-in-pipe solution, where the outer pipe is a 0.4 mm thick flexible hose with an outer diameter only 1 mm smaller than the borehole. An inner pipe is then inserted into the outer pipe. The borehole fluid flows down through the central pipe, and up through the annulus (the flow direction was not found to effect the performance of the borehole HX (Holmberg, Acuña et al. 2016)). The results showed about 50 % reduction in borehole resistance, compared to U-tube collectors.

3.1.2 Systems and energy balance

The most common solution for GSHP systems is individual systems for each building, or set of connected buildings. For residential buildings, which normally do not have cooling demand, the main energetic benefit of GSHP compared to air source heat pumps (ASHP) is a stable heat source temperature throughout the year. As shown in Figure 2.5, the performance of heat pumps is dependent on the temperature difference between the source and the heating system. Therefore GSHP system will normally have considerably higher seasonal performance factors (SCOP) than ASHP systems.

For buildings with cooling demand, there are additional benefits. After the heating season, the bedrock temperature is reduced and needs reheating. These low temperatures enable rejection of heat from the building into the boreholes, by direct heat exchange between the collector circuit and cooling circuit in the building. This has a double effect, as it regenerates the borehole and supplies cooling of low energy cost (free cooling). With no, or insufficient, cooling, the boreholes must be regenerated by other means. This can either be an additional heat source such as a dry-cooler or available surplus heat, or the borehole field must be large enough so that the heat from the surrounding bedrock is enough for regeneration. With a good balance between cooling and heating the demand, the number of boreholes can also be reduced, due to less degradation of the storage over time and less need for heat exchange between the borehole field and the surrounding bedrock.

A challenge for borehole systems is often the high peak cooling loads. The bedrock has relatively low thermal conductivity, which means that the heat uses a long time to distribute away from the borehole. Therefore, the temperature of the collector fluid can rise rapidly (over hours) during high loads. Systems are therefore often designed in such a way that the heat pump can supply cooling to the building, and the surplus heat from the condenser is dumped into the borehole. For some building categories (e.g. offices and schools) the cooling capacity at peak load can be the dimensioning factor for the heat pump and borehole field.

In neighbourhoods with a mix of different building categories, there can be a positive effect of connecting the buildings to a common GSHP system, both due to the simultaneity factor and that buildings with high cooling demand can benefit from the cooling of the bedrock produced by the buildings with high heating demand and vice versa.

GSHP heating and cooling systems in buildings can be integrated using two different principles. Either a central heat pump system with distribution of hot and cold water, or a decentralized system with distribution of the collector fluid with individual heat pumps for buildings or building complexes.

Central heat pump systems

The most common solution is to have individual GSHP systems for each building, or set of connected buildings. In a neighbourhood context this would be a central heating and cooling plant connected to a borehole field, distributing hot and cold water through a piping network.

The main benefit with such systems is lower installation cost for the heat pump systems and end user substations, and easier operation and maintenance compared to a distributed system with several heat pumps.

Vulkan, Oslo (Rohde, Bantle et al. 2015)

At the Vulkan building cluster in Oslo, a GSHP systems connects a total area of about 38 000 m² heated floor area containing a food court, offices, residential apartments and a hotel in an integrated energy system. The system delivers refrigeration in the food court, space heating and cooling, domestic hot water and heating for snow melting.

The system consists of five heat pumps /cooling machines connected to a borehole field of 64 wells, 300 m deep. Solar collectors are used for heat production and regeneration of the bedrock. District heating is used for peak load and backup. A simplified drawing of the system is shown in Figure 3.3.

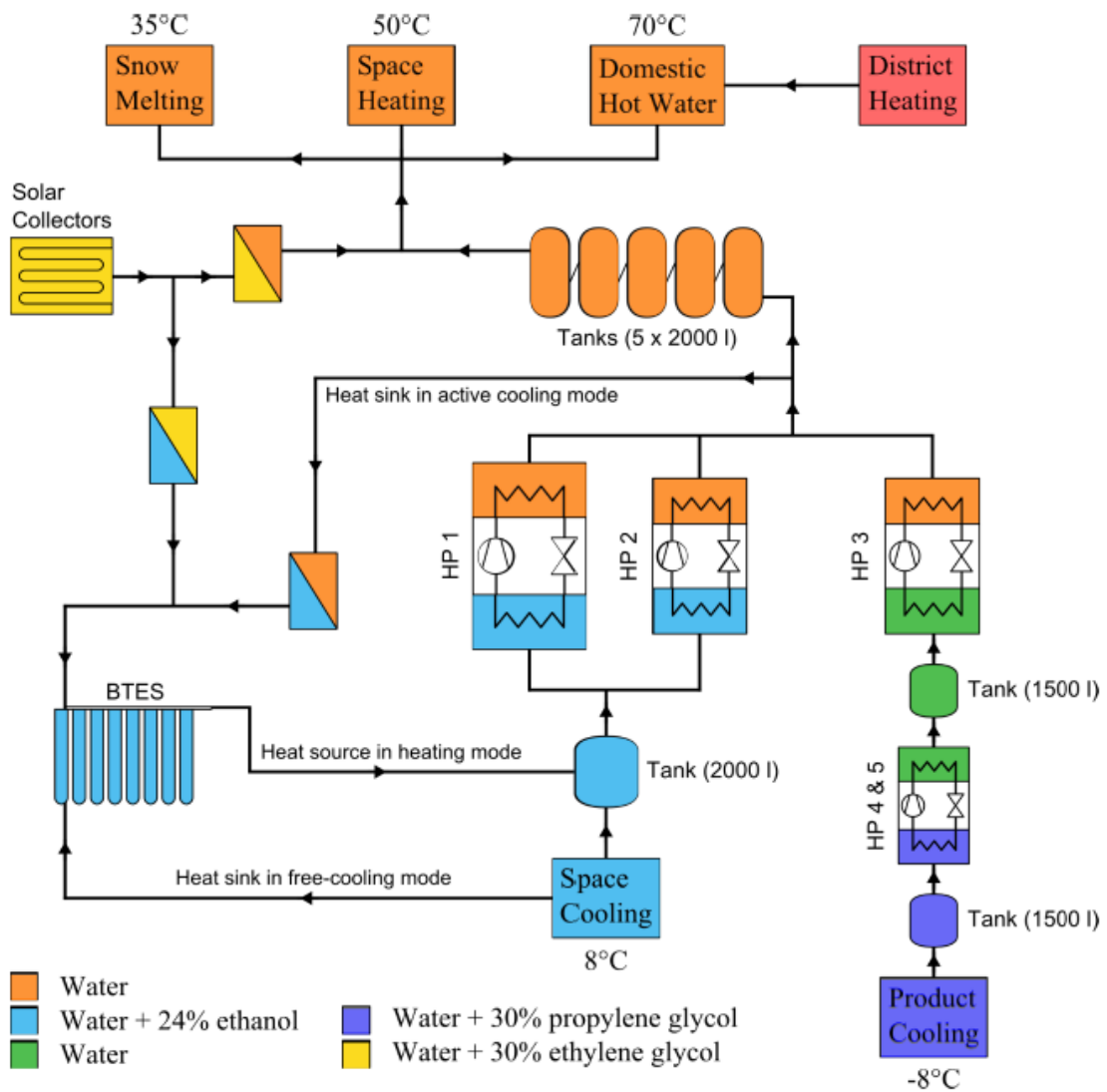

Figure 3.3:
Simplified system layout at Vulkan (Rohde, Bantle et al. 2015)

Figure 3.4 shows the monthly energy balance and average COP of the system in its first full year of operation. The system COP ranges from 1.7 to 3.4.

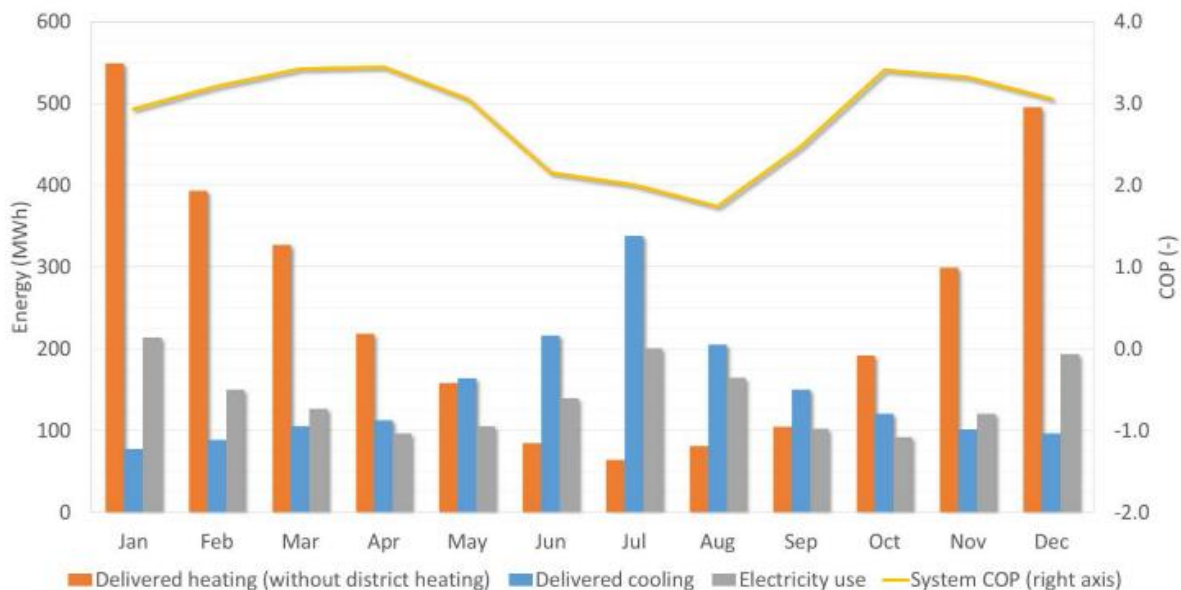

Figure 3.4:

Heat and cold production and COP in 2014 (Rohde, Bantle et al. 2015)

(Rohde, Andresen et al. 2016) studied the possibility for exporting heat to the DH system during periods with excess heat. The system has a yearly heat excess that is dumped into the boreholes. This would lead to a gradual heat up of the ground and reduced cooling capacity. If heat could be exported to the DH network during summer, it could improve the overall performance. The study showed that it is feasible to export heat, but the temperature levels of the DH network must be reduced from today's level.

Nydalen Energi

An example of such a system is the Nydalen energy central in Oslo. The energy central was established in 2003, with 180 boreholes, 200 m deep each (Avantor 2017a). In 2014 it was expanded with a biomass boiler and heat pumps using Akerselva as heat and cooling source (Avantor 2017b). The energy central delivers heat to 295.500 m² and cooling to 270.000 m² floor area. Heat from cooling of non-residential buildings with data centres keeps the annual energy balance, and the borehole heat exchangers enable surplus heat from summer to be utilized during winter. In 2016 about 60 % of a total 21 GWh heat was delivered from the heat pump system.

Moholt 50/50 (Abrahamsen and Laskemoen 2017)

Another example is the Moholt 50|50 project in Trondheim. This is a student housing area with a mix of old and new buildings, including a kindergarten and a library. The energy system includes 23 boreholes, 250m deep, with charging from solar collectors, waste water and the building ventilation system. The system is designed with a supply temperature of 55 °C to increase the COP. A water treatment system¹ is installed to avoid legionella, since DHW is stored at relatively low temperatures.

¹ www.apurgo.no

Distributed heat pump systems

An alternative to the single central heat pump system is to distribute the collector fluid as a "cold" energy carrier in the network. Distributed heat pumps serving either a single building or a cluster of buildings use the fluid as heat source and deliver the necessary temperature for the local buildings. The cold energy network can be used directly for cooling purposes (e.g. non-residential buildings or data centres) and recovery of waste heat from distributed sources.

The main characteristics of such systems are their ability to use the heat demand for some buildings to supply efficient cooling for other buildings throughout the year, through a single set of pipes. There are almost no thermal energy losses in the main distribution network, since the temperature level is approximately equal to the ground temperature. Also the distributed heat pumps make it possible to adjust the temperature level to the needs of the individual building. This is a large benefit for neighbourhoods with an existing building stock. Compared to individual GSHP system for each building, the cold energy network yield lowers the number of boreholes, both due to heat and cold interaction between buildings, and because of simultaneity factors.

Such a system has been investigated at ZEN pilot Furuset (Norconsult 2014) but is currently not chosen for further investigation. This is mainly because of cost.

Berlin-Zehlendorf, Germany (Geo-En 2016)

An example of such a system is the residential area in Berlin-Zehlendorf, with 22 houses, 135 apartments and total 21 000 m² floor space. Here a cold energy network with borehole heat exchangers connects clusters of buildings with heat pump. In addition, solar collectors are used for regeneration of the thermal storage, and a CHP plant produces electricity for the heat pumps and heat to part of the buildings. A principle drawing of the system is shown in Figure 3.5

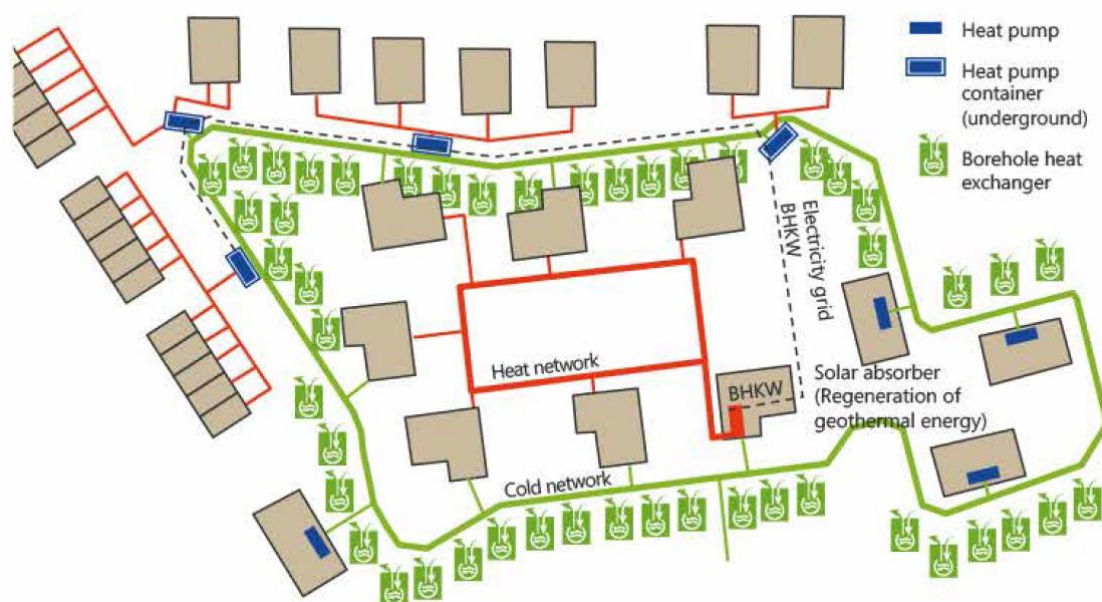

Figure 3.5:
Berlin-Zehlendorf cold energy network (Geo-En 2016)

Zurich, Switzerland (Kolb 2015)

Several such systems have been implemented in Zurich: Network "Campus Höggerberg" (Swiss Federal Institute of Technology), Network Friesenberg and Network Richti Areal. These networks are referred to as "anergy networks". Anergy is the part of heat energy that cannot be converted into work, the rest is exergy (Gundersen 2009).

Common for all these networks are that they consist of a mixture of buildings with both heating and cooling demand, but with non-simultaneous peaks. In the Friesenberg Network, which is illustrated in Figure 3.6, the Swisscom Data Center is cooled by the network, and supplies heat to the remaining buildings.

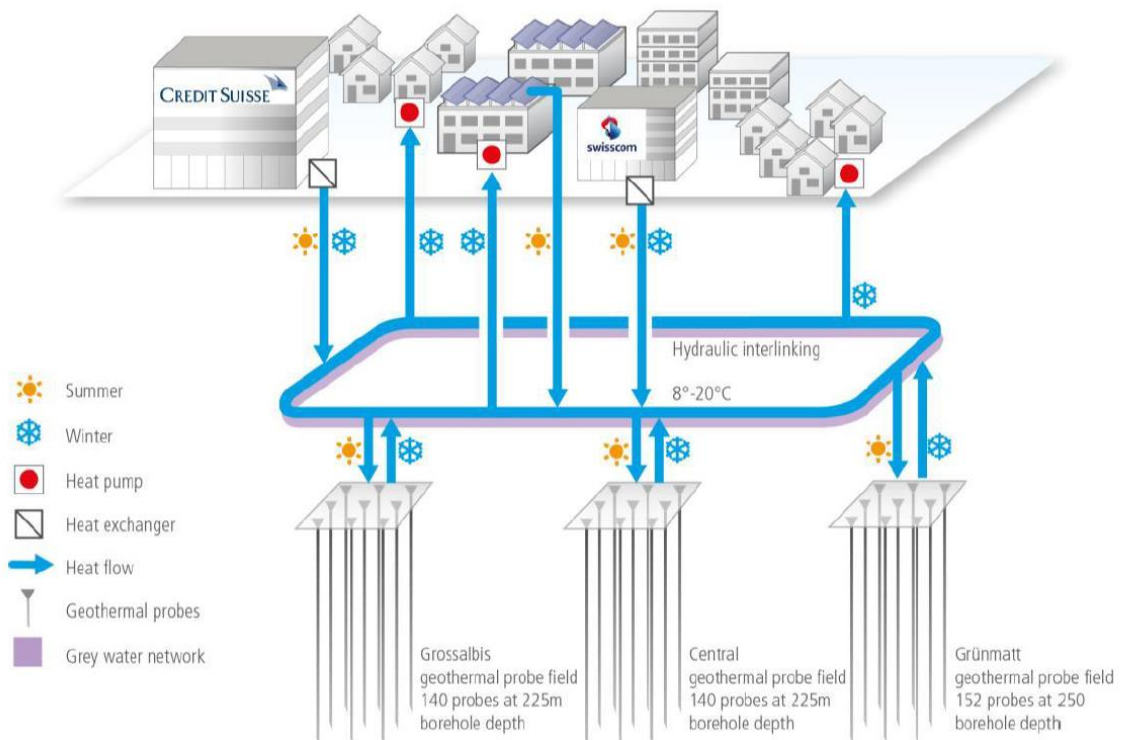

Figure 3.6:
Principle drawing of "Anergy" networks in Zurich (Kolb 2015).

3.1.3 Dimensioning of borehole fields

The necessary size of the borehole field is determined by two main factors: the thermal profile of the connected system, and the performance of the borehole field itself.

The thermal profile of the system is of course dependent on the user profile of the connected buildings. The profile can be divided into two main properties:

1. The long term energy profile (kWh). This is the energy balance between heating and cooling load that is extracted from the boreholes during the operation years. In dimensioning calculations it is usually expressed as kWh/month or kWh/year. It can also be expressed as kWh/year per meter borehole. The energy balance influences the overall temperature in the borehole field through the years of operation. If the heat load is too high compared to the size of the borehole field, the temperature will gradually drop, and in the worst case, there are risks of freeze out (permafrost).

2. The short term power peaks (kW). This is the maximum loads that are extracted from (heating) or injected into (cooling) the boreholes for short periods. Due to the low thermal conductivity and high thermal capacity of the rock, the heat moves slowly through the ground. At high peak loads, a small area around the borehole will cool down (heat extraction) rapidly, and the temperature of the collector fluid is reduced. This can result in inability to satisfy heating or cooling needs or short term freeze out around the borehole. Multiple freeze-outs increase the risk of frost heaving damages on the borehole.

The key to designing an efficient borehole system is to balance the yearly cooling and heating demand and to minimize the peak loads. For modern buildings (e.g. offices and schools) the challenge is often that the cooling loads have very high peaks, with a low yearly energy demand.

The performance of the borehole field is determined by the borehole thermal resistance (R_b) and the properties of the ground. The borehole thermal resistance is discussed in section 3.1.1. The main unknown thermal properties of the ground are the effective thermal conductivity (λ_{eff}) and the undisturbed ground temperature (T_∞). These properties can be measured through a thermal response test (TRT). The concept of TRT is thoroughly described in (Gehlin 2002). In short, a borehole heat exchanger is inflicted with a constant heat load through the circulation collector fluid, while the temperatures are measured. From the measurements and a set of assumptions, it is possible to calculate R_b , λ_{eff} , T_∞ . A TRT is quite costly, and for smaller borehole fields, it is common to make conservative assumptions for these values.

Simulation tools

With the known thermal load, and the borehole properties, it is possible to size the borehole field with adequate simulation tools. There is a large set of available simulation tools on the market, with varying complexity and user friendliness.

(Persson, Stavset et al. 2016) has done a comparison of a selection of tools available on the market. The results are summed up in Table 3.1. In general, there is always a trade-off between details and flexibility vs. user-friendliness. The most user friendly models, such as EED and Polysun, lack some flexibility for modifications, while the more flexible tools, such as Modelica and TRNSYS (open source code), demand more from the user. IDA ICE is defined as being somewhere in the middle.

Another relevant parameter is the ability to simulate both the borehole heat exchangers and the thermal system together. This is relevant, due to the way the systems interact with each other. For example, the temperature from the borehole influences the COP of the heat pump, which influences the amount of heat extracted from the borehole, which again influences the temperatures in the borehole. Most tools, with the exception of EED, have models for the heating system on various levels. IDA ICE and TRNSYS have detailed multi-zone building models. There exist also several libraries with building models for Modelica², and an IBPSA project has just started as a continuation of the Annex 60 "New

² [AixLib](#), from RWTH Aachen University, Germany.
[Buildings](#), from LBNL, Berkeley, CA, USA.
[BuildingSystems](#), from UdK Berlin, Germany.
[IDEAS](#), from KU Leuven, Belgium.

generation computational tools for building and community energy systems based on the Modelica and Functional Mockup Interface standards"³.

Table 3.1: Comparison of borehole heat exchanger simulation tools (Persson, Stavset et al. 2016)

Platform	Borehole models	User aspects		Time step		Borehole and ground properties										Type of BHX					Geometry					Documentation
		User friendly	Level of flexibility (open source code)	Time step down to 60s	Preconditioning	Input of measured borehole resistance R_b from response test	Multiple vertical nodes (layered ground)	Undisturbed temperature in the ground (adjustable)	Ground water movement	Grouting heat capacity	Grouting thermal conductivity	Borehole diameter	Single U-collector	Double U-collector	Coaxial collector	Smooth or rough inner shape	Time dependent mass flow rate	Multiple boreholes	Non-uniform spacing of boreholes	Boreholes charged in series	Boreholes charged in parallel	Sloping boreholes	Variable load for boreholes/ independent operation of boreholes			
TRNSYS	Type 281 (TRNSBM)	N	Y	Y	Y	Y	Y	Y	N ³	N ¹	Y	Y	Y	Y	N ¹¹	Y	N ¹¹	Y	Y	Y	Y	Y	Y	Y	Pahud (2012) Pahud et al. (1996b) Eskilson (1986)	
	Type 557 (TRNV DST)	Mid	Y	Y	Y	N	Y	Y	N	N ¹	Y	Y	Y	Y	N	N	Y	Y ¹⁰	N	Y	Y	N	N	Pahud et al. (1996a) Mazzarella (1993) Hellström (1989)		
	Type 451 (EWS)	Mid	Y	Y	Y	N	Y	Y	N	Y	Y	Y	Y	N	N	N	Y	N	N	N	N	N	N	Wetter and Huber (1997)		
Polysun	EWS	Y	N	Y	Y	N	Y	N ⁷	N	Y	Y	Y	Y	Y	Y	Y	N	Y	Y	Y ⁹	N	Y	N	N	Huber and Schuler (1997b) Huber and Pahud (1999)	
IDA ICE	GHX	Y	N ²	Y	N	Y	N	Y	N	Y	Y	Y	Y	N	N	Y	Y	Y	N	N	Y	Y	N	N	EQUA Simulation AB (2013)	
Modelica	INTERACT 2015	N	Y	Y	N	N	Y	Y	N	Y	Y	Y	Y	Y	N	N	Y	Y	N	Y	Y	N	N	N	Holstad (2015)	
	INTERACT 2016	N	Y	Y	N	N ⁸	Y	Y	N	Y	Y	Y	Y	Y	N	N	Y	Y	Y	Y	Y	Y	N	Y	Developed in project INTERACT 2016	
Matlab/Simulink+Carnot		Mid	Y	Y	Y	Y	N ⁴	Y ⁵	N	Y ⁶	Y	Y	Y	N	N	Y	Y	Y	N	N	Y	N	N	N	Ochs (2012)	
EED		Y	N	N	N ¹²	Y	N	Y	N	N	Y	Y	Y	Y	Y	N	N	Y	N	Y	Y	N	N	N	Hellström and Sanner (2000) Blomberg et al. (2015)	

- 1) The heat capacity of the grout and pipe can be taken into account by adding a pipe with heat capacity (Pärisch et al., 2015).
- 2) Source code is open but cannot be modified
- 3) There is another version of the model (Type 280) to simulate energy piles with ground water flow (Pahud et al., 1996)
- 4) Layering of the ground is not implemented in Carnot but is supported by the EWS algorithm
- 5) Connected by g-function (g-function create the boundary conditions for the near pipe area)
- 6) Pipe heat capacity not included
- 7) Undisturbed ground temperature given by the selected location
- 8) Would be a very simple addition to the model
- 9) Requires also the EWS-programme by Huber and Pahud (1999)
- 10) Only cylindrical borehole storages
- 11) Could be taken into account using R_b from thermal response test and externally calculated pipe to pipe resistance R_a
- 12) Not required due to the fast calculation and that the model cannot be implemented in a system

For sizing of conventional borehole fields, the less flexible, but more user-friendly models can be satisfactory. However, more novel concepts (such as high temperature storage systems discussed in section 3.2), need more flexibility to adapt the models to the concept.

Some of the models have been validated against measurements; however, there are little reliable long-term data available for complex systems, so validation results are limited (Persson, Stavset et al. 2016).

³ <https://ibpsa.github.io/project1/>

3.1.4 Cost

(Ramstad 2011) did an investigation on cost for GSHP systems in Norway, combining surveys on installed systems and modelling based on vendor quotes. The results are shown in Figure 3.7, divided into different capacity ranges (2011 prices). The non-coloured marks are based on models, while the coloured marks are from surveys. The results do not show the effect of geological conditions, which will have a considerable effect on both cost and feasibility. Most of the results are in the area of 15 000 kr/kW and 50 øre/kWh, which is representative for medium to large scale heat pumps in areas with shallow deposit layers. The costs include the complete system of boreholes and heat pumps, but not the internal distribution system inside the building.

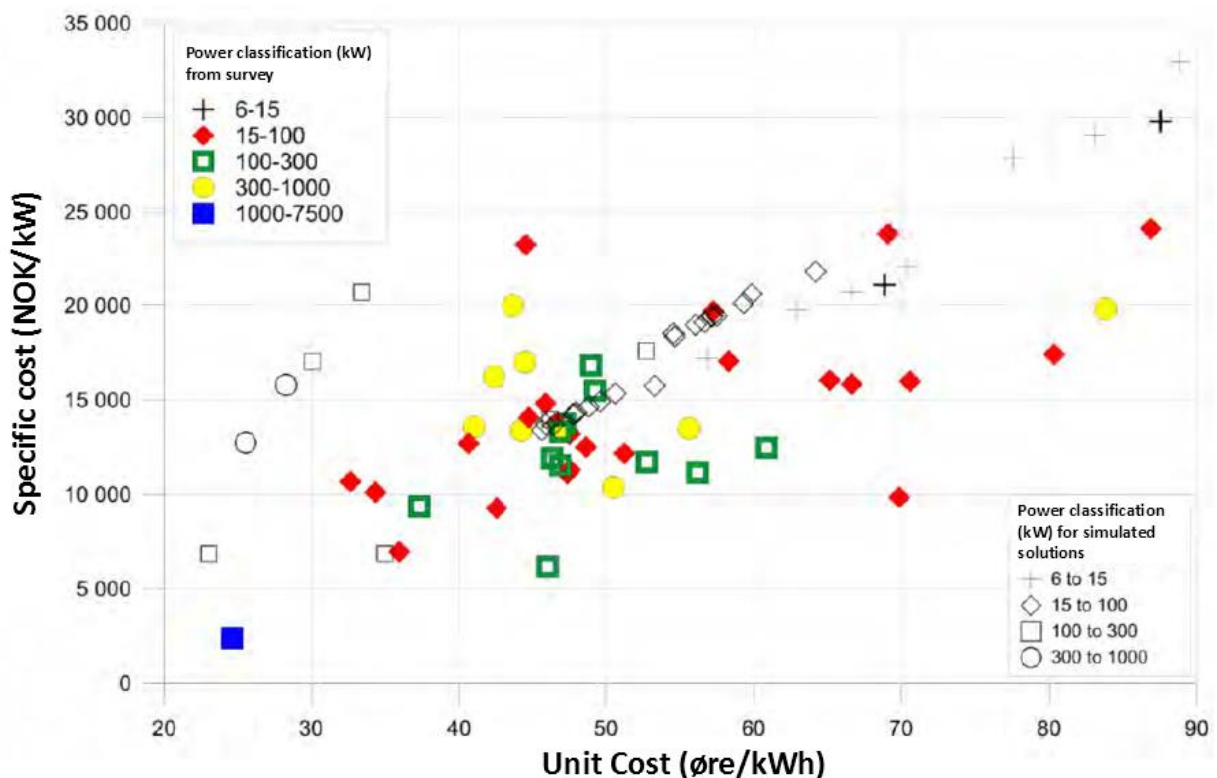

Figure 3.7:
Specific power costs and energy unit costs for GSHP systems in Norway (Ramstad 2011)

3.2 High temperature seasonal heat storage

For many cases there is a seasonal mismatch in the produced/available heat and the demand. Typical examples are waste incineration plants with approximately constant amount of waste heat throughout the year due to the landfilling prohibition (KLD 2009), and solar thermal plants with peak production during summer. It would therefore be interesting to store surplus heat during summer, for use during winter. Such systems are often denoted Seasonal Thermal Energy Storage (STES). The ZEN pilot case Furuset is currently studying the possibility to store surplus heat from the waste incineration plant at Klemetsrud, at a local borehole field at Furuset, for either direct use in a local thermal grid, or as heat source for a heat pump.

Large scale STES systems have been investigated in Europe since the 1970s, with the first demonstration plants in Sweden in 1978/79. During the 1990s, mainly Germany lead the investigation through projects on large scale solar collector systems (Mangold and Deschaintre 2012). In the last years, the technology has received more interest through projects in Europe (e.g. PIMES, EINSTEIN, PITAGORAS and SUNSTORE 4) and Canada (Drake Landing⁴). Norway's first large scale solar collector system was built by Akershus Energi at Kjeller. It has a 1200 m³ storage tank that works for short term load shifting, but no seasonal storage (Akershus Energi AS 2017).

Most research and demonstration projects on large-scale seasonal storage systems are done in relation with solar collector system, in order to increase the share of solar heat in a district/neighbourhood heating system (Schmidt, Mangold et al. 2003, Lundh and Dalenbäck 2008, Mangold and Deschaintre 2012, Sibbitt, McClenahan et al. 2012).

3.2.1 Systems for seasonal storage

Thermal storage technologies can be categorized into three different types:

- Sensible heat storages (temperature difference)
- Latent heat storages (phase change)
- Thermo-Chemical storages (chemical reaction)

This report will focus on sensible heat storage technologies, as these are the most promising and economically feasible solutions for the large scales necessary for long-term storage (Mangold and Deschaintre 2012).

Sensible heat storage technologies can be further divided into four categories, illustrated in Figure 3.8. TTES and PTES are systems that are separated and insulated from the ground, and the internal medium (water or gravel-water mixture) is used for thermal storage. BTES and ATES are systems that are integrated with the ground, and the bedrock or groundwater is used for storage.

⁴ www.dlcs.ca

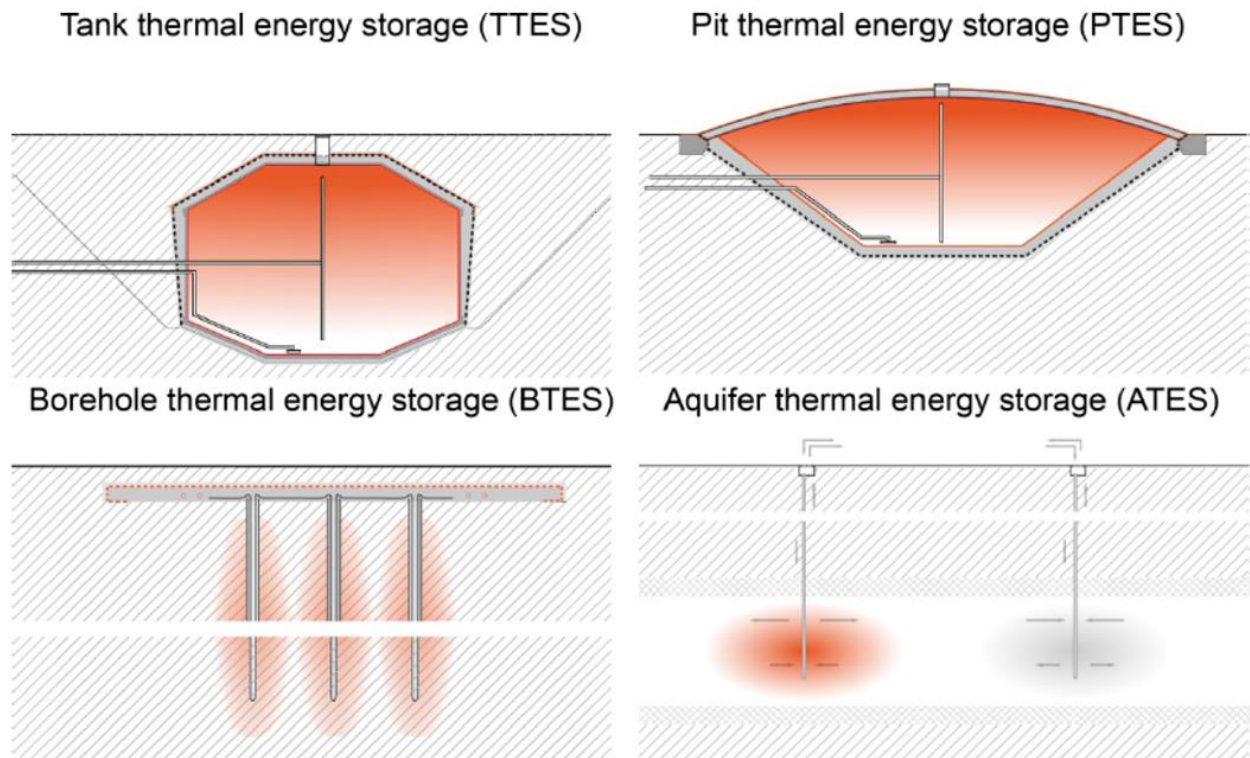

Figure 3.8:
Illustration of different sensible thermal energy storage systems (Mangold and Deschaintre 2012)

Tank thermal energy storage (TTES)

Seasonal TTES is in principle a large underground water tank, usually made of reinforced concrete. Water is used directly as storage medium. During charging, hot water is supplied at the top and colder water is extracted at the bottom. During discharging, the flow is reversed.

The storage tank can be pressurized, and the operating temperature can therefore be higher than in the other systems. It is also the system with the best surface/volume ratio, and therefore also the system with potential for lowest thermal losses. The thermal capacity is high, at 60-80 kWh/m³, but it is also the most expensive system to install (Mangold and Deschaintre 2012).

Pit thermal energy storage (PTES)

PTES is an artificial pool filled with storage material and with a lid. The bottom, sides and lid can be insulated and lined with watertight plastic foil. One challenge with the design is the construction of the lid. It can be built as a self-supporting structure, or as a floating structure (typical solution in Denmark). However, often the pit is filled with a water-gravel mixture (GWTES) that supports the lid. This also simplifies the construction if the space over the structure should be used for other purposes (e.g. parking lot or playground).

The PTES normally operates at atmospheric pressure, and the temperature must therefore be below 100 °C. Due to the plastic lining the temperature is normally limited to 90 °C (Schmidt, Mangold et al. 2003). Filled with water, the thermal capacity is similar to that of TTES, while with GWTES, the

volumetric thermal capacity is reduced to 30-50 kWh/m³. It is, however, a cheaper construction than TTES (Mangold and Deschaintre 2012).

Borehole thermal energy storage (BTES)

The borehole heat exchangers in high temperature BTES system are similar to that of a GSHP system described in section 3.1, though the boreholes are normally shallower and more numerous. The borehole field is insulated on the top, but not downwards along the edge. To reduce the heat losses the boreholes are divided into parallel strings of boreholes connected in series towards the centre Figure 3.9. During charging, hot water is pumped into the wells in the centre, through the BHE series and out from the wells along the edge. During discharge, the flow is reversed.

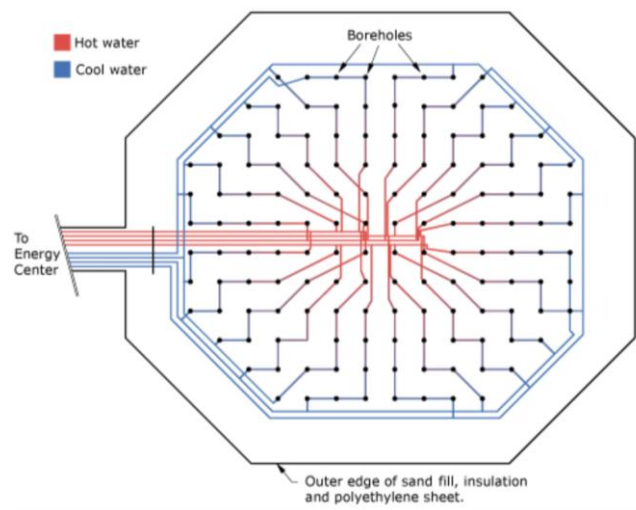

Figure 3.9:
Typical layout of high temperature BTES system (DLSC 2017)

Storage in dry rock structures allows for high temperatures, but the standard plastic collector pipes are limited to about 90 °C (Schmidt, Mangold et al. 2003). High temperatures might also influence the surrounding ground in undesirable ways. The volumetric thermal capacity is significantly lower than TTES at 15-30 kWh/m³, but volumetric installation costs are much lower (Mangold and Deschaintre 2012).

Aquifer thermal energy storage (ATES)

ATES utilizes naturally occurring self-contained underground layers of ground water. Separate injection and extraction wells are established. Water flows through the ground between the wells. The flow is reversed when changing from charging to discharging.

ATES systems are very dependent on the correct ground conditions, but if favourable, it is often the most cost effective solution. However, due to underground bio-chemistry, ATES are typically limited to maximum operating temperatures around 50-60 °C (Tecnalia 2015) . The thermal capacity is typically in the range between PTES and BTES, at 30-40 kWh/m (Mangold and Deschaintre 2012)

General aspects and comparison

The most suitable storage solution is dependent on many factors and must be evaluated in each project. Table 3.2 gives a comparison of the main properties of the storage systems. Figure 3.10 shows some installed and planned STES, with installation costs as function of size. The size is transformed to equivalent water volume, to be comparable.

Table 3.2: Comparison of STES systems (Mangold and Deschaintre 2012, Tecnalía 2015).

	TTES	PTES	BTES	ATES
Temperature in the STES	Up to 98 °C for non-pressurized TTES	Up to 90 °C. Usually max 80-85 °C	Up to 90 °C. Usually 60-75 °C	Usually maximum 50-60 °C
Surface/Volume ratio	Low	Medium	High	High
Insulation	Insulated in all surfaces	Usually insulated at all surfaces, but poorer than TTES	Only insulated at top.	None
Heat losses	Low	Medium	High	High
Ground properties requirements	Beneficial if ground water level is below tank installation (5-15m)	Should avoid ground water above installation level (5-15 m)	No or very low groundwater flow. Solid rock or water saturated soil	Aquifer with high porosity, high hydraulic conductivity, small groundwater flow, and vertically enclosed and leak-proof layers
Volumetric Storage capacity	60-80 kWh/m ³	30-80 kWh/m ³	15-30 kWh/m ³	30-40 kWh/m ³
Charge/discharge capacity	High	High-Medium depending on direct or indirect system	Low, often requires additional short term tanks	Medium
Required Area/Volume	Low	Low to medium. Depending on pure water or gravel-water mixture. Can be challenging to utilize space above	High, but surface above can be utilised for other purposes	Low
Investment cost	High	Medium	Low	Lowest

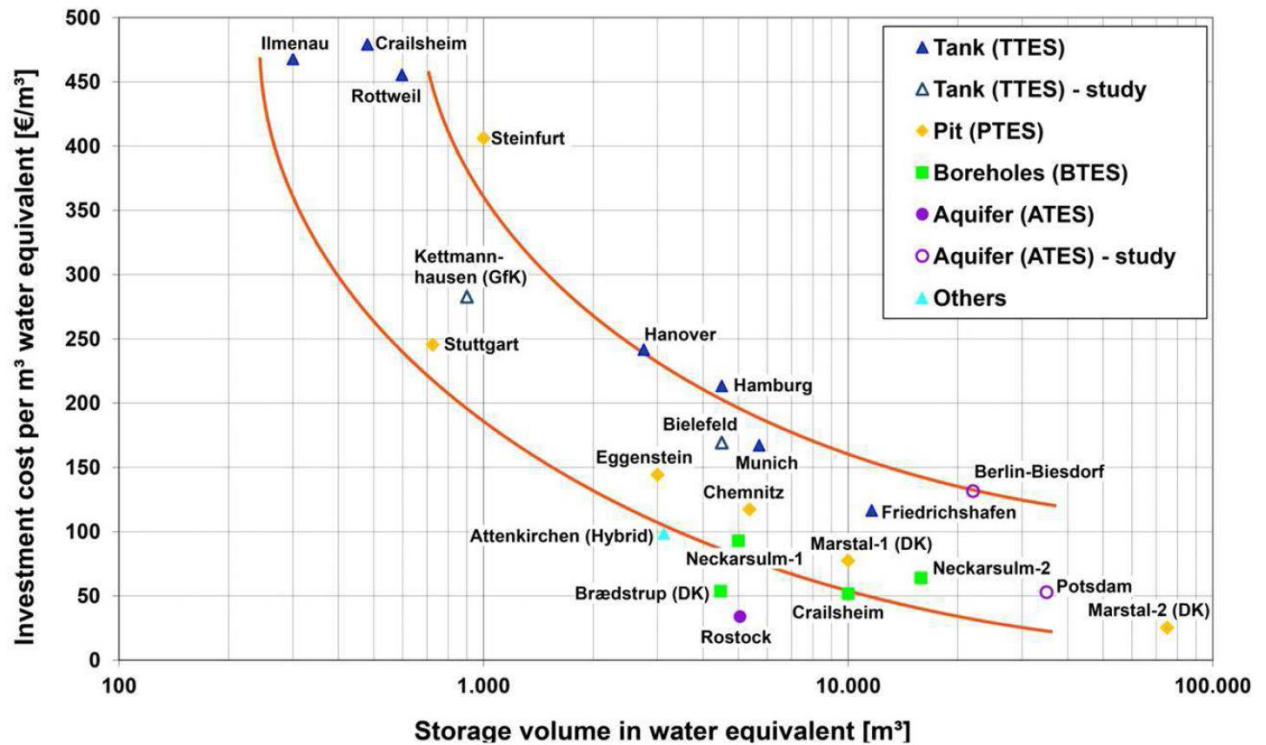

Figure 3.10:
Investment cost for STES systems (Tecnalia 2015)

As seen from Table 3.2, TTES have many benefits, but are mainly hampered by the large investment cost. The low heat loss properties and high cost, makes it more beneficial for smaller capacity systems. PTES and BTES are more common for large systems. Especially BTES needs a certain size to be feasible (20 000 m³ according to (Mangold and Deschaintre 2012)). PTES is generally more efficient than BTES, but the necessary surface space is not always available, and with BTES, the surface above can more easily be utilized for other purposes. ATES can be a very good solution, but the ground properties must be suitable. As with BTES, ATES is most common for low temperature storage with heat pumps, but there are examples of relatively high temperature ATES systems (Kabus, Möllmann et al. 2006).

3.2.2 Important parameters for the connected thermal network

STES is a complex and high cost solution for improved energy efficiency, and is only recommended for systems where other simpler measures are already implemented or not feasible (Mangold and Deschaintre 2012).

The main parameter for efficient integration of STES in a thermal network is the temperature levels. The supply temperature in the heating network dictates the temperature level in the STES. The lower the temperature, the lower the heat losses. In addition, the temperature difference between the storage and the return from the heating network defines the volumetric storage capacity, as the storage capacity is a function of the heat capacity of the storage material and the temperature difference.

For GWTES, BTES and ATES charging and discharging capacities are limited. Therefore, peak loads in the thermal network should be reduced. Often additional short-term storage tanks are necessary. A

larger temperature difference between the STES and the heating network increases the discharge capacity, but increases the heat loss.

STES systems are normally used to increase solar fraction in heating networks. Typical design fractions are above 50 %. In all cases, additional heat sources are necessary. This could be typical peak load and backup sources such as boilers or connected district heating systems. It is also common to install heat pumps, which can utilize the heat storage as heat source when the temperature is too low for direct use.

(Nilsson, Hargö et al. 2016) studied a concept with local BTES storages located in connection with a new or renovated building connected to district heating. This would make it possible to design the building heating system to match the properties of the BTES. The main principle is to use direct district heating for DHW purposes and utilize the BTES for heating purposes with low temperature systems. The results from the study show that economic and environmental benefits of such projects are largely dependent on local conditions and the energy mix of the DH system. Also the calculation assumptions, such as energy mix factors and allocation of emissions have large impacts on the results. Due to the low energy consumption of new buildings, it is difficult to make the concept economically attractive. However, a common system for a group of buildings (e.g a neighbourhood) would increase the attractiveness.

3.2.3 Examples

Below, some examples of installed STES systems are described.

TTES in Munich-Ackermannbogen, Germany (Reuss 2016)

A TTES system is installed connected to solar collectors and a low temperature local heating network to increase solar fraction. The storage tank contains 5700 m³ of water with a total storage capacity of 480 MWh (15/90 °C). The system is also connected to an external district heating system, and utilizes a district heating driven absorption heat pump when the temperature of the thermal storage gets too low. Yearly heat loss according to design calculations was 80 MWh. Results from the two first years of operation showed significantly higher heat losses (221 MWh year 1 and 195 MWh year 2). The heat losses could be expected to be reduced after some years of operation, as stable temperatures around the tank are reached. A solar fraction of 45% was reached the 2nd year of operation.

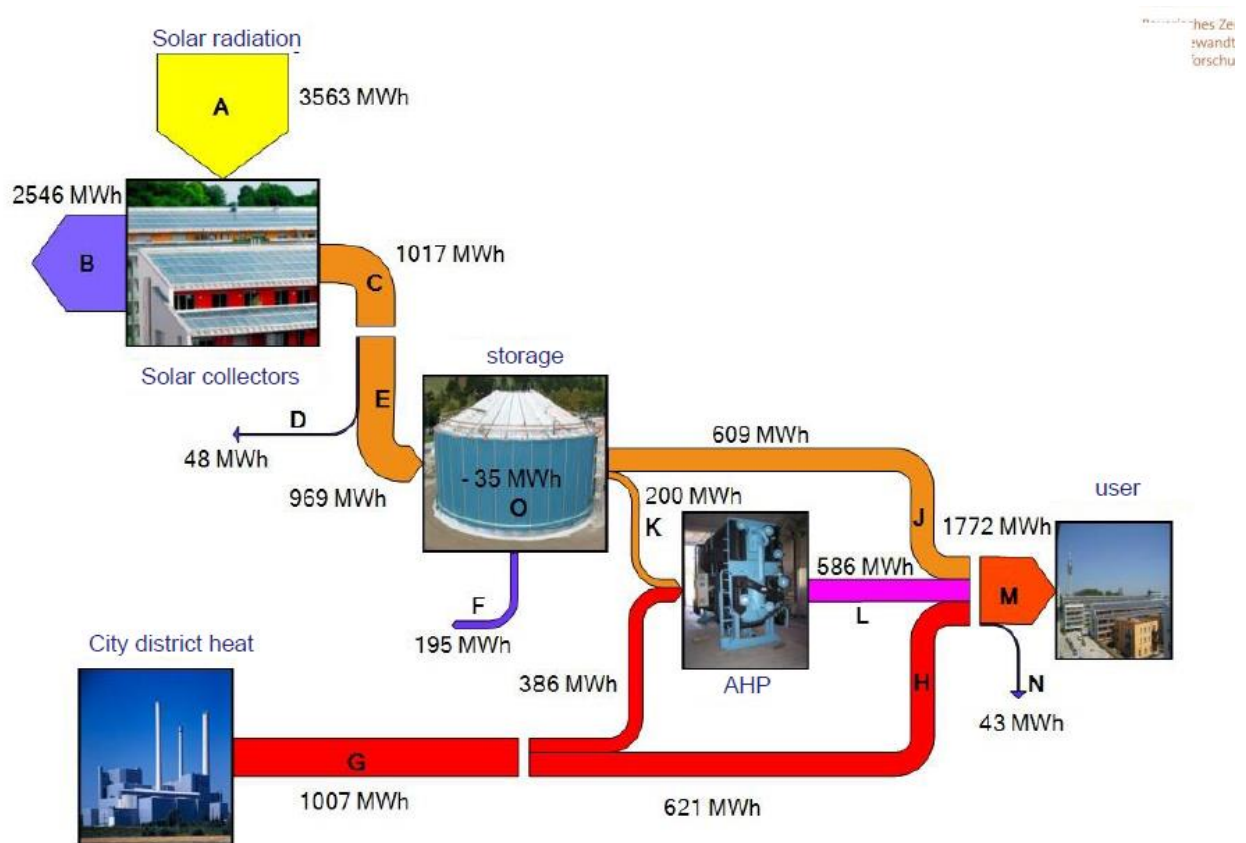

Figure 3.11:
Energy flows 2nd year of operation of Munich-Ackermannbogen TTES (Reuss 2016)

PTES Marstal, Denmark (Jensen 2014)

Marstal District heating has built two PTES systems for their district heating system, to increase the solar fraction. The first was built in 2003, with a capacity of 10 000 m³ water. Later this has been expanded with a 75 000 m³ PTES. The latter has a storage capacity of 6 960 MWh (90/10 °C) and a discharge power of 10,5 MW. The system is connected to 33 300 m² of solar collectors, a 1,5 MW heat pump, a 4 MW wood chip boiler and a 750 kW Organic Rankine Cycle. The system operates with a solar fraction of 50-55 %

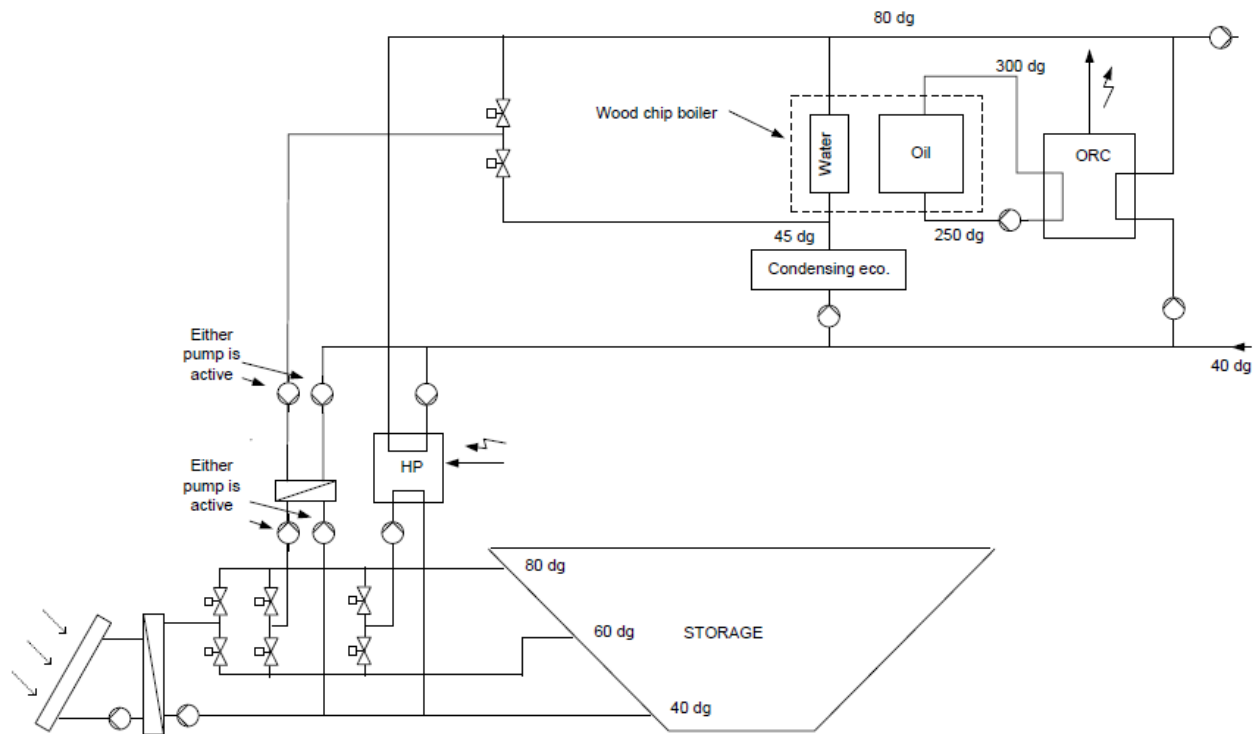

Figure 3.12:
System configuration of Marstal District Heating (Jensen 2014)

Drake Landing Solar community, Okotoks, Canada

In Okotoks, Canada, 52 detached energy efficient houses are connected to a local heating grid with solar collectors and a BTES system. The BTES system consists of 144 boreholes, 35 m deep. The BTES utilizes an earth volume of 34 000 m³. In addition there are two short-term storage tanks with a combined volume of 240 m³ to even out short-term variations, as the BTES system reacts slowly. After five years of operation, the target of >90 % solar fraction was reached. After stable conditions were reached (after approximately 4 years) the BTES efficiency has been between 35 and 55 %. More details on the project can be found at the DLSC website (www.dlsc.ca).

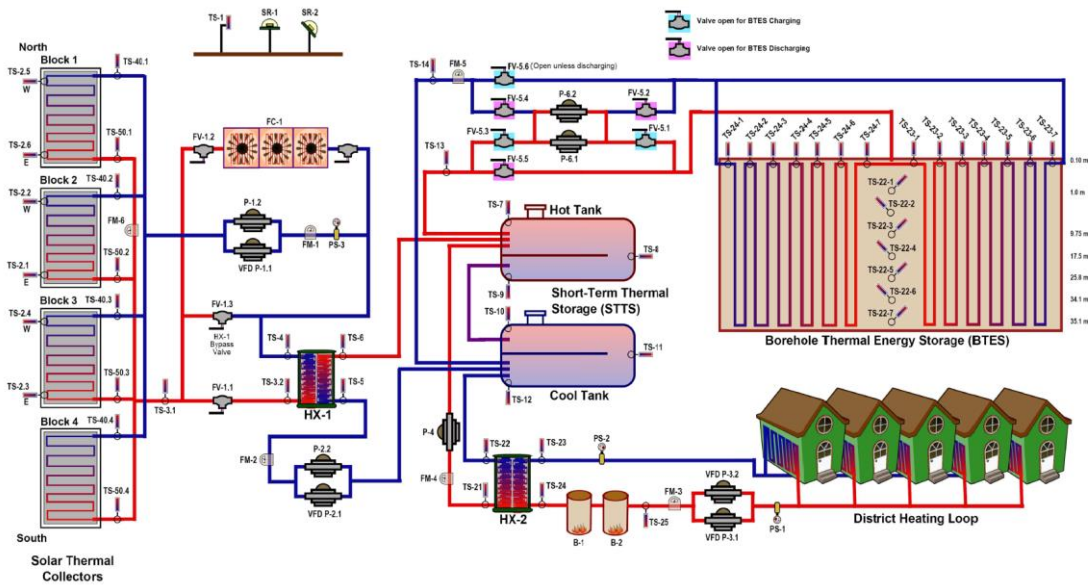

Figure 3.13:
DLSC system layout (Sibbitt, McClenahan et al. 2012)

Hefaistos project, Linköping Sweden (Lindståhl 2017)

Tekniska Verken in Linköping is currently studying the possibility to store surplus heat from waste incineration during summer, for use during winter (similar to the proposed concept at the ZEN pilot Furuset). The goal is to store 70 GWh of heat from summer to winter. They are studying a BTES concept with around 1500 boreholes, 300m deep. The connection type is not decided yet, and they are looking at several options, such as parallel or series with the boilers and also an option with an absorption heat pump.

4 Small scale CHP

The invention of the steam engine accelerated the industrial revolution initially making mechanical production in factories possible, but engineers soon discovered the possibility to utilize the waste heat for heating the factory, and hence the concept of combined heat and power was invented more than two centuries ago (Knowles 2011).

With the need to reduce emissions and an increased focus on decentralized energy production, the CHP-technology has experienced increased popularity. Worldwide roughly 90 % of the installed CHP capacity is within the large scale i.e. greater than 2 MW but there has been considerable growth, especially in the small and micro range in recent years. Small scale is typically defined between 100 kW and 2 MW and micro below 100 kW (Knowles 2011).

Within the framework of FME ZEN mainly the small and micro range is of interest. Moreover, in a zero emission perspective, the CHP-technology is only relevant with non-fossil fuels.

4.1 CHP technology status

Small and micro cogeneration is relevant for single buildings or in small-scale district heating systems. All CHP technologies currently available, except fuel cells, are heat engines. (Frydenlund 2010) lists the following division of technologies in the small and micro CHP range:

- Heat engines
 - Internal combustion engines
 - Reciprocating (Otto cycle, Diesel cycle)
 - Gas turbines (Brayton cycle)
 - External combustion engines
 - Organic Rankine Cycle (ORC) (Rankine cycle)
 - Stirling engines (Stirling cycle)
- Electrochemical
 - Fuel cells

Heat engines are all combustion engines, whereas fuel cells rely on the highly exothermic chemical reaction between hydrogen and oxygen in order to produce electricity and heat.

Some CHP technologies (Stirling, ORC) can utilize solid biomass directly. ORC can also utilize low temperature heat. Other CHP technologies use biogas, which may be produced externally or locally. Externally produced biogas has a relatively high CO₂ factor, due to emissions related to gasification and transport. Locally produced biogas from biomass has a lower CO₂-factor (the one of the solid/liquid biomass used as primary source), but it implies lower overall efficiency due to the energy consumed by the gasifier.

Reciprocating gas engines have been chosen for two of the FME ZEB demo cases, Campus Evenstad and Heimdal High School; both have had biogas CHPs with internal combustion engines. At Evenstad, the CHP has a local gasifier installed, using wood chips as the energy source. At Heimdal, it is planned to use externally produced biogas.

4.1.1 Reciprocating engines

Reciprocating internal combustion engines include Otto and Diesel cycle engines (see Figure 4.1), commonly known from the automotive industry. The technology is well known and mature, has been subject to extensive research over the years and has proven performance and reliability. Other benefits include relatively low specific investment cost, high power/weight ratio, short start-up time, good load modulation and multi fuel capability (Frydenlund 2010). Weaknesses include high level of noise and vibration and the need for specialist maintenance.

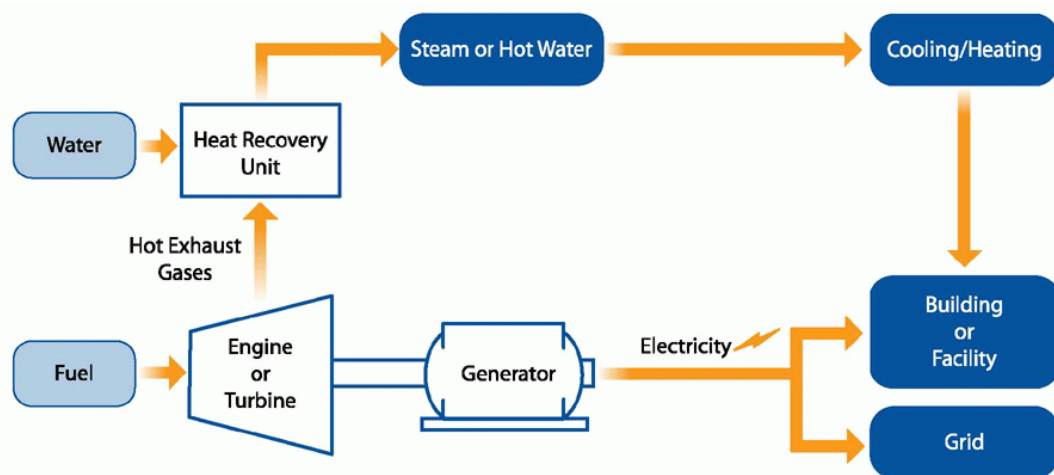

Figure 4.1

Schematic for typical CHP with either reciprocating engine or micro turbine (EPA 2017)

4.1.2 Gas turbines

Essentially, small gas turbines are originally developed for automotive turbochargers, but are increasingly utilized in auxiliary power units and CHP applications over the last 20 years (Backman and Kaikko 2011). Micro turbines have fewer moving parts than reciprocating engines and are thus potentially more reliable (Frydenlund 2010). The micro turbine has high exhaust gas temperatures ideal for heat recovery, but is dependent on a recuperator pre-heating the combustion air in order to increase the electrical efficiency from 15 % towards 30 % (Simrader, Krawinkler et al. 2006). Externally produced biogas is a possible non-fossil fuel for the micro gas turbines. It is also possible to use solid biofuel and to produce biogas locally in a gasifier. In a gasifier, the solid biomass is thermally converted to synthesis gas. Gasification of biomass demands high fuel quality as well as making the total system more complex. Both higher fuel quality and increased complexity will add to the overall cost of the system (Skreiberg 2011).

4.1.3 Organic Rankine Cycle (ORC)

The steam turbine Rankine cycle is the most commonly used process for electricity generation, for instance in coal and nuclear power plants. The Organic Rankine Cycle is similar (see Figure 4.2), but utilizes an organic fluid with high molecular mass instead of steam, which allows exploiting low temperature heat sources in order to produce electricity (Simrader, Krawinkler et al. 2006). Like the micro gas turbine, the ORC turbine has fewer moving parts than the reciprocating engine. Because the ORC gets the energy driving the cycle transferred externally, an obvious benefit with ORC is the ability to work with any kind of heat source; for instance low price biomass such as woodchips. ORCs

are flexible systems with good performance also at part load. See chapter 4.5.2 for a case study of an ORC-based district heating plant.

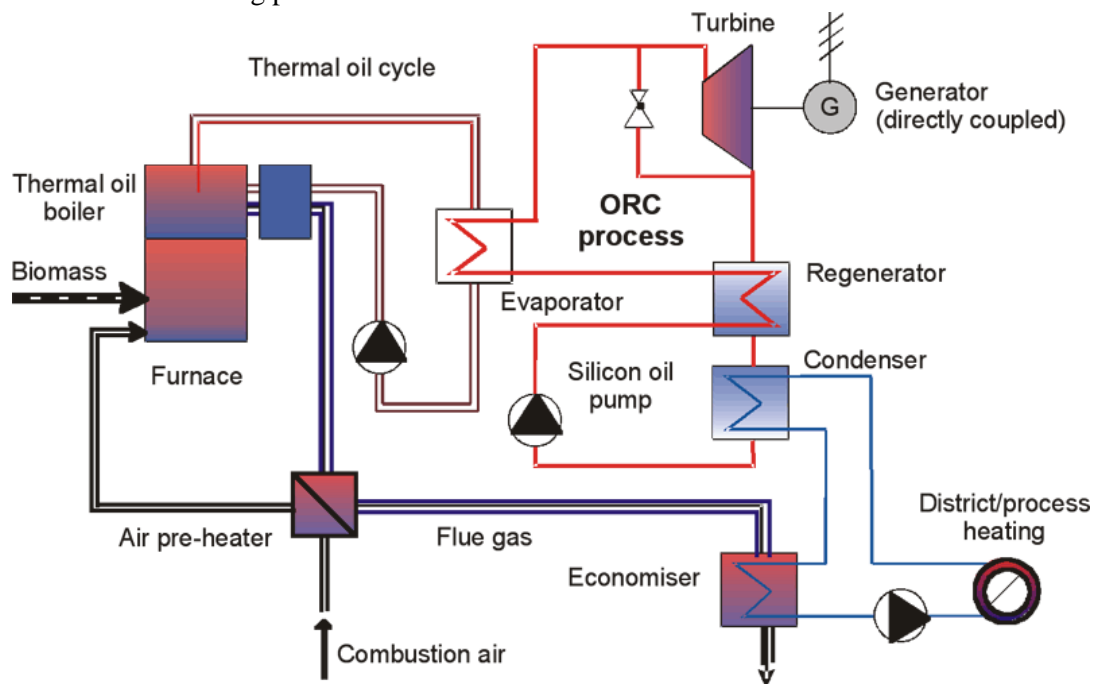

Figure 4.2
ORC CHP System (Obernberger, Carlsen et al. 2003)

4.1.4 Stirling engine

The Stirling engine is an external combustion engine where a working fluid within a closed system is driven by externally applied energy (heat). This means the cycle itself, and hence the electricity generation, is decoupled from the thermal production and is hence highly versatile regarding what type of fuel is being used. See Figure 4.3. The Stirling engine works well with low temperature heat sources and can consequently work well with solar thermal energy or waste heat. The Stirling engine has quiet operation, high (theoretical) efficiency and good performance at part-load. But this technology is still relatively expensive, and due to the external heat source, the dynamic power modulation is poorer than for other technologies. Biomass can be used as a renewable heating source, and in some cases solar thermal.

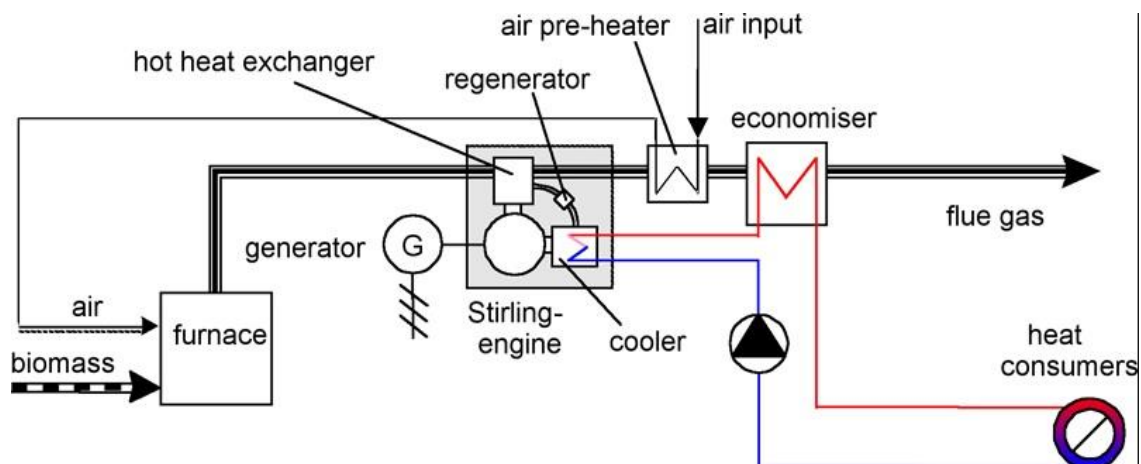

Figure 4.3
Stirling Engine CHP System (BIOS 2017)

4.1.5 Fuel cells

Fuel cells convert chemical energy of a fuel into electricity and heat. Unlike all the other relevant CHP technologies, fuel cells do not rely on combustion to generate power and heat. There are several types of fuel cell technologies under development, but in order to be relevant for small- and micro-CHP uses there are still barriers such as cost-effectiveness, safety and operation lifetime. There are basically two relevant and commercially available technologies (Brett, Brandon et al. 2011):

- PEFC
- SOFC

The biggest practical difference between PEFC, polymer electrolyte fuel cell (also often referred to as PEMFC, Proton Exchange Membrane-, or SPFC, Solid Polymer-), and SOFC, solid oxide fuel cell, is the operating temperatures. The former typically works in the range of 30-200 °C and the latter 500-1000 °C (Brett, Brandon et al. 2011, Ellamla, Staffell et al. 2015). PEFC fuel cells can reach electrical efficiencies around 25-35 % and overall CHP efficiencies towards 90 % and the SOFC technology around 45-55 % electric and 90 % overall (Ellamla, Staffell et al. 2015).

Both technologies demands hydrogen with high purity because impurities will affect the lifetime of the electrodes. Most commercially available fuel cells utilize hydrogen converted from natural gas. For use of biogas it should be considered that it is recovered from sewage, manure, food waste and landfill, and is therefore a less pure gas with more contaminants. Depending on the source, the biogas will have different composition of chemical substances, several of which can damage and decrease lifetime of fuel cell components. In a recent study (Lanzini, Madi et al. 2017) the authors conclude that removing of biogas contaminants is feasible with current technology but that further research is needed to improve the cost-effectiveness.

Fuel cells are quiet and have low local emissions because no combustion is taking place. However, the fuel cell technology is, and has been for several years, relatively costly compared to other CHP relevant technologies. Further developments may make fuel cell technology more commercially competitive in the future.

4.2 Financial aspects

In a global perspective, most of the installed CHP capacity today is fossil fuel heat engines. Obviously, fossil fuels are ruled out in a ZEN perspective. The Norwegian KRAV project (Skreiberg 2011) addressed possible small scale biomass CHP solutions for the Norwegian market. The report concludes that the low electricity price is a major barrier for CHP market penetration and that only low cost biomass can yield cost effective electricity production. The scope of the CHP technology within the KRAV project was mainly at a larger scale than in ZEN. One reason being that the smart energy neighbourhoods still were only in the idea phase at the time, and a second being that the KRAV project as a backdrop had the Norwegian governments' goal of doubling the Norwegian bioenergy use from 14 TWh (2008) to 28 TWh in 2020.

The final report concludes that larger scale is more profitable, because investment cost per installed power decreases with increasing plant size, and that probably both green certificates (still not introduced in 2011) and other financial support such as governmental funding through Enova is

needed. But it finishes saying that small and micro scale plants still might have a cost effective future if an optimal configuration, considering all possible benefits are taken into account, is achieved.

CHP technology comparisons

Efficiency (el)						
Very good	Carbon fuel cell, Gas fuel cells, SOFC-GT	BIGCC				
Good		Gas turbines, Micro gas turbines		Steam turbines, Gas engines		
Fair		Stirling engine, Hot air turbine	ORC			
Poor			Steam engines			
Very poor						
		Very poor	Poor	Fair	Good	Very good
		Economy				

Figure 4.4

CHP technology comparison. Efficiency (el) versus economy (Skreiberg 2011)⁵

4.3 Widespread CHP: The Danish model

According to the Danish Energy Agency (DEA 2015), in 2014 Denmark had a total district heating supply of 33,8 TWh, where 68,9 % was covered by CHP plants, mostly fuelled by natural gas. Throughout Denmark there are CHP plants in all sizes, and there was a significant increase in production from small CHP plants from 1990 up to 2000. However, due to lower electricity prices there has been a slight decrease in recent years (also from large scale CHP).

The DEA expects the production of district heating from CHP to decrease drastically towards 2050 due to energy efficiency measures in the building stock and increased electricity production from wind. With a lower thermal energy demand and hence fewer full load hours, the cost of producing thermal energy, and consequently electricity, from CHP plants will increase making this technology less competitive. The heat generated by CHP is expected to be replaced by a combination of wind power, heat pumps and electric boilers, by industrial waste heat, and by solar thermal.

4.4 CHP in a ZEN perspective

Regarding the aspects of load matching and grid interaction, for both electrical and thermal energy, CHP technology makes a good partnership with PV. When CHP is operated primarily as a heat source, the electricity production, and hence eventual electricity surplus, will be greatest in winter when the heating demand is higher. Also, the flexibility offered by a heat storage tank (which is required to allow the CHP unit to work at optimal load or else rest) makes it possible to operate the CHP to follow signals from the grid, thus making it a flexible Distributed Energy Resource (DER).

⁵ BIGCC stands for Biomass Integrated Gasification Combined Cycle, like the example in 4.5.1

A PV installation will, on the other hand, naturally produce more electricity during the summer months. A combination of CHP and PV can therefore be designed to fit together both on a yearly basis and on an hourly level, in order to optimize the load matching/grid interaction. This is illustrated in Figure 4.5 and Figure 4.6, showing the power export from a single family house in Germany with CHP and a single family house in Denmark with PV and heat pump, respectively. The contour graphs beneath shows the hours of the day on the horizontal axis, the days of the year on the vertical axis and the electricity import/export as colours. The respective colour scales are given in the upper right-hand corner. Positive value means export whereas negative value implies import.

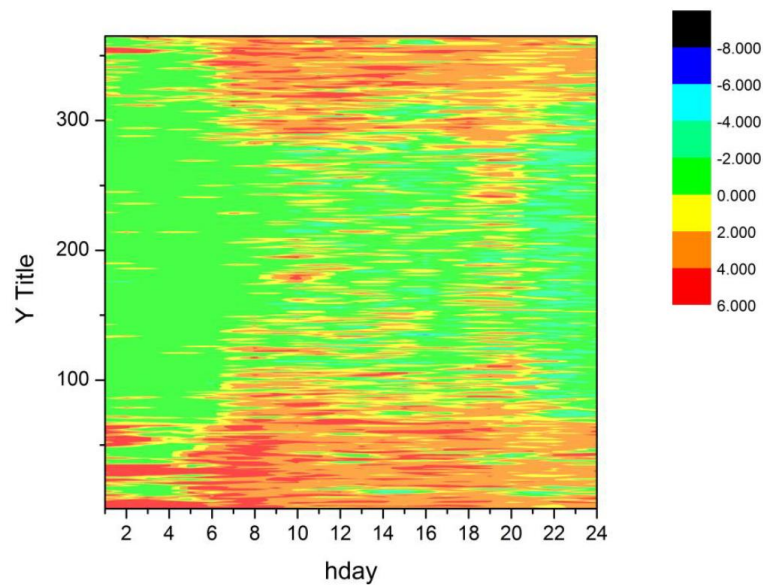

Figure 4.5

Contour graph of net exported energy for multifamily house in Germany with CHP (Salom, Marsal et al. 2013).

Left y-axis exported power (kW)

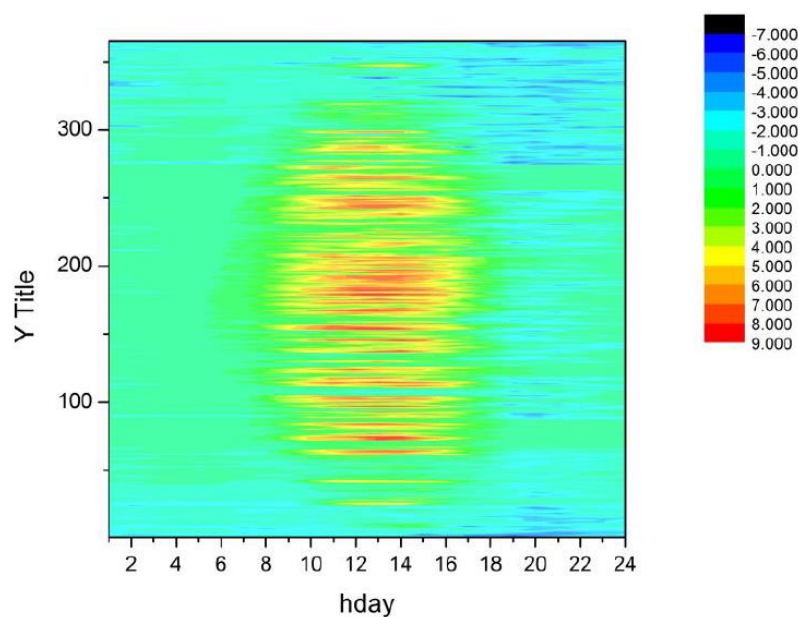

Figure 4.6

Contour graph of net exported energy for single family test facility house in Denmark with heat pump and PV (Salom, Marsal et al. 2013). Left y-axis exported power (kW)

4.5 Case studies

4.5.1 Campus Evenstad

Campus Evenstad, a university college in Norway and a pilot case in both the ZEN and the former ZEB research centres, has a gas engine CHP with gasifier installed. Here woodchips are locally gasified, and the gas thus obtained is used for the internal combustion engine that runs the generator. Heat from the process is recovered into water.

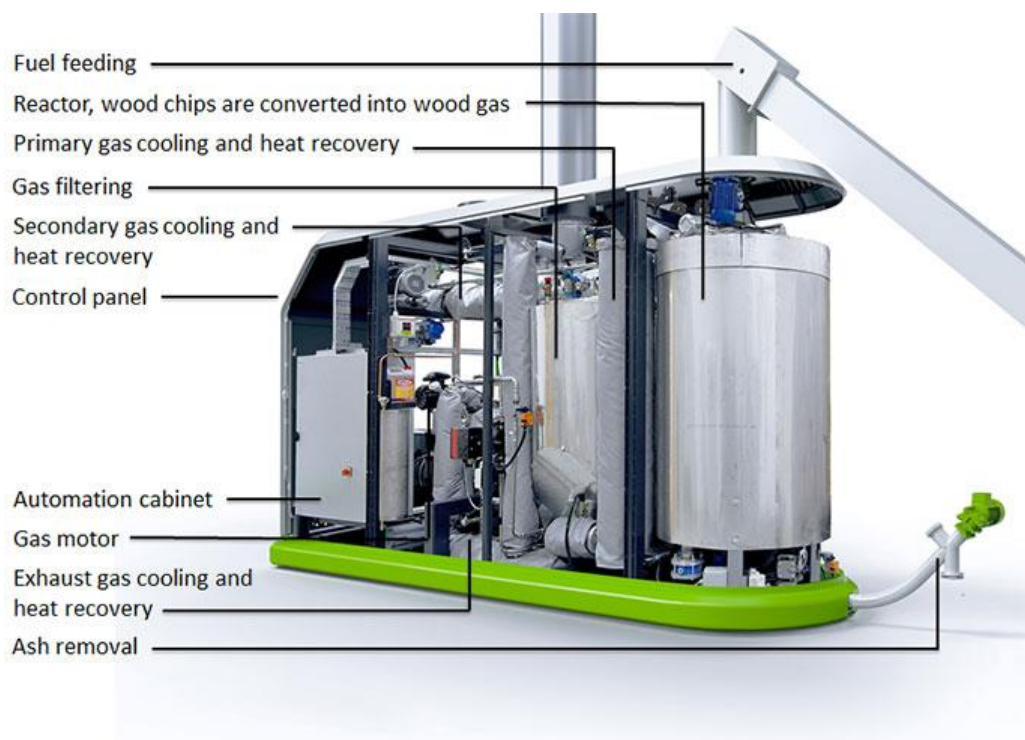

Figure 4.7
CHP installation Evenstad (www.volter.fi)

The initial choice was an ORC, but it proved difficult to obtain, so the gas motor CHP was chosen instead. Reasons for choosing this solution were:

- Limited roof space available for PV and the need, as a ZEB pilot, to get closer to a zero emission balance. The combination of CHP and PV was evaluated positively, as discussed in §4.4;
- Good access to solid biomass (the campus is located in a forestry region);
- Eagerness to install a system with high degree of innovation and which would provide new knowledge in the Norwegian context (Statsbygg is a government developer).

According to the producer, the unit can yield 40 kW electrical and 100 kW thermal power with a total efficiency of 70 %. Calculations (Statsbygg 2017) estimate that the unit will run 3500 equivalent full load hours and produce 133 MWh_{el}/year and 325 MWh_{th}/year. Early operational experiences have

been promising, and it may be possible to increase the number of operational hours. The CHP unit has high quality requirements to the wood chips used.

The total cost for the CHP installation, including some extra construction work and equipment as well as training of personnel, amounted to 5.5 MNOK. Statsbygg has applied for green certificates for the produced electricity. This will be the first green certificates given to bioenergy-based electricity in Norway.

4.5.2 ORC South Tyrol

In South Tyrol in northern Italy there are 70 district heating plants based on biomass, and a dozen of these are ORCs. One of these ORC-based district heating plants is in Renon, Bolzano (Prando, Renzi et al. 2015). The plant consists of a woodchip-fed moving grate furnace boiler and an ORC generator producing $1,0 \text{ MW}_{\text{el}}$ and $4,9 \text{ MW}_{\text{th}}$ at nominal conditions. The electricity is entirely fed into the national grid, and the heat is supplied at a nominal temperature of $90 \text{ }^\circ\text{C}$ to 250 users, consisting of single family houses, apartment buildings and hotels.

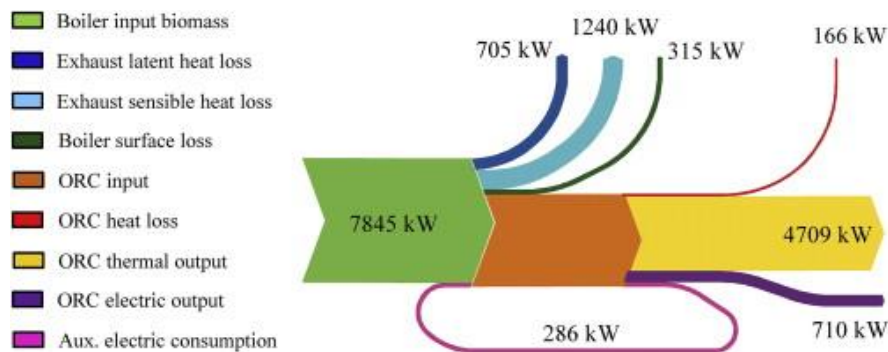

Figure 4.8

Sankey-diagram of the ORC-system at 94 % load (Prando, Renzi et al. 2015)

Figure 4.8 shows the energy flow of the system at 94 % load. The total efficiency (at lower heating value) is 69 %.

About half of the thermal energy generated by the ORC unit is used for drying the woodchips, but the drying only occurs when the heating production is greater than the demand from the district heating system. Figure Figure 4.9 shows the load duration curves for both district heating demand and ORC output where the thermal energy used for drying woodchips is the area in between.

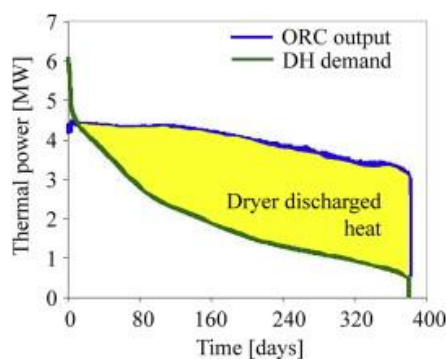

Figure 4.9

Load duration curves (Prando, Renzi et al. 2015)

The district heating demand is greater than the ORC output for a very short period and is covered by a backup diesel boiler.

Due to the subsidisation of electricity from renewable sources and the fact that this CHP plant exports all of the generated electricity to the grid, the paper concludes that it is economically advantageous to run the ORC at nominal load to maximise the electrify generation, even though this means discharging part of the thermal energy. Another conclusion is that the drying could be done more efficiently.

In a ZEN perspective the operation would have needed to be optimized with regard to local electricity demand, local heating demand and interaction with other energy sources, and with the overall efficiency as a directing parameter.

4.6 CHP technology summary

The various technologies under the CHP umbrella cover a wide range of power outputs, temperature levels and fuel capabilities, meaning that CHP is a highly versatile option when designing the energy flexible neighbourhood. However, total cost for both installation and operation is relatively high compared to other technologies. The CHP technology might play a role in the future energy mix for the energy flexible neighbourhood, as long as the CHP installation is locally optimized and is not challenged by other more cost effective renewable energy sources.

5 Conclusion

This report summarizes some of the main technologies relevant for thermal networks in the ZEN pilots. Thermal supply in ZENs can be divided into three subsystems: Production, distribution and the interaction with buildings.

When designing thermal energy systems in ZENs, the focus should be on developing systems that utilize the flexibility and interaction benefits of an integrated system, while minimizing the disadvantages, such as infrastructure costs and distribution losses.

An integral part in enabling a flexible and efficient thermal energy supply will be low temperature systems. Both the production and the distribution systems will benefit from low temperatures through higher efficiency and lower losses, while it is the system inside the buildings and their interaction with the distribution network that must be designed to enable use of low temperatures.

To increase the flexibility of thermal networks and interaction between buildings, some sort of energy storage is necessary. However, storage will always come with losses, and finding the right trade-off between the benefit of flexibility and storage losses will be an important optimization problem in the design of ZENs

This report has mainly focused on heat networks, as heat normally represents a considerably higher energy consumption than cooling. However, the benefit of operating with temperatures as close to ambient as possible also applies to cooling, and it is important to utilize the interaction benefits of the two demands.

The best choice of production or supply system, whether it is connection to a nearby district heating network, GSHP system with integration of heating and cooling or CHP, will depend both on the properties of the neighbourhood itself and the surrounding conditions.

CHP consists of a broad range of technologies, each with their characteristic benefits and challenges. A properly designed CHP system interacts well with other renewable energy sources and might play a role in the Zero Emission Neighbourhood

One of the main goals in moving from ZEB to ZEN is to reduce the risk of sub-optimisation of local solutions. However, neighbourhoods are still often small systems in the overall solution. This is especially important to consider when investigating complex and costly infrastructure concepts (e.g. large scale seasonal storage systems). These systems will last for many years, and a good solution today might not be the best solution in 20 years.

6 References

- 4DH. (2017). "4dh web page." Retrieved 18.04.2017, from <http://www.4dh.eu/>.
- Abrahamsen, K. and K. Laskemoen (2017). Moholt 50/50 - Presentation for HPCY 2017. DecarbHeat 2017, Brussels, Belgium.
- Acuña, J. (2010). Improvements of U-pipe Borehole Heat Exchangers, KTH School of Industrial Engineering and Management.
- Acuña, J. (2013). Distributed thermal response tests – New insights on U-pipe and Coaxial heat exchangers in groundwater-filled boreholes. Phd, KTH School of Industrial Engineering and Management.
- Akershus Energi AS. (2017). "Solfangeranlegget." Retrieved 28.06, 2017, from <http://akershusenergi.no/no/energi-varme/varmesentraler/akershus-energi-park/solfangeranlegget>.
- Avantor. (2017a). "Nydalen energisentral." Retrieved 30.05.2017, from <http://avantor.no/nydalen-energi/>.
- Avantor. (2017b). "Utvidelse av Nydalen Energi." Retrieved 30.05.2017, from <http://avantor.no/utvidelse-av-nydalen-energi/>.
- Backman, J. and J. Kaikko (2011). Microturbine systems for small combined heat and power (CHP) applications. Small and micro combined heat and power (CHP) systems. R. Beith, Woodhead.
- Ben Hassine, I. and U. Eicker (2013). "Impact of load structure variation and solar thermal energy integration on an existing district heating network." Applied Thermal Engineering **50**(2): 1437-1446.
- BIOS. (2017). "Description of the biomass CHP technology based on Stirling engines." from <http://www.bios-bioenergy.at/en/electricity-from-biomass/stirling-engine.html>.
- Boverket (2011). BBR – Boverkets byggregler.
- Brett, D. J. L., N. P. Brandon, A. D. Hawkes and I. Staffell (2011). Fuel cell systems for small and micro combined heat and power (CHP) applications. Small and micro combined heat and power (CHP) systems. R. Beith, Woodhead Publishing.
- Dalenbäck, J.-O. (2015). Solar District Heating in Europe - Guideline for end-user feed-in of solar heat. SDHplus.
- Dalenbäck, J.-O., G. Lennermo, P.-E. Anderson-Jensen and P. Kovacs (2013). Solvärme i fjärrvärmesystem – Utvärdering av primärkopplade system (Solar Heating in District Heating Networks – Evaluation of Primary-Connected systems). Swedish District Heating Association. **Report 2013:26**.
- DEA (2015). Regulation and planning of district heating in Denmark. D. E. Agency.
- DLSC. (2017). "Borehole Thermal Energy Storage (BTES) " Retrieved 12.06, 2017, from <https://www.dlsc.ca/borehole.htm>.
- DVGW (2004). DVGW-Arbeitsblatt W 551.
- EGEC (2017). 2016 EGEC Geothermal Market Report - Key Findings. L. Angelino, P. Dumas, T. Garabetian and V. Pinzuti.
- Ellamla, H. R., I. Staffell, P. Buljo, B. G. Pollet and S. Pasupathi (2015). "Current status of fuel cell based combined heat and power systems for residential sector." Journal of Power Sources **293**(October 2015): 16.
- EPA. (2017). "Combined Heat and Power." from <https://www.epa.gov/chp/what-chp>.
- Flores, J. C., O. L. Corre, B. Lacarrière and V. Martin (2014). Study of a district heating substation using the return water of the main system to serve a low-temperature secondary network. The 14th International Symposium on DH and Cooling, Stockholm, Sweden.
- Fortum. (2017). "Öppen fjärrvärme." Retrieved 14.06, 2017, from <https://www.oppenfjarrvarme.se/>.
- Frederiksen, S. and S. Werner (2013). District Heating and Cooling, Studentlitteratur AB.
- Frydenlund, F. (2010). Survey of Available Technologies for Renewable Energy Supply to Buildings. ZEB, The Research Centre on Zero Emission Buildings.
- Gehlin, S. (2002). Thermal Response Test. Phd, Luleå University of Technology.

- Geo-En (2016). Highest efficiency with the cold network. Geo-En. http://www.geo-en.de/images/en/referenzen/pdf/2_CLA_A4.pdf.
- Gundersen, T. (2009). An Introduction to The Concept of Exergy and Energy Quality. Department of Energy and Process Engineering, Norwegian University of Science and Technology, Trondheim, Norway.
- Hafslund Varmer AS (2017). Bestemmelser om tilknytning til hafslunds varmes fjernvarmenett for nybygg. Dokument 15/00578-1.
- Hassine, I. B. and U. Eicker (2014). "Control Aspects of Decentralized Solar Thermal Integration into District Heating Networks." Energy Procedia **48**: 1055-1064.
- Holmberg, H., J. Acuña, E. Næss and O. K. Sønju (2016). "Thermal evaluation of coaxial deep borehole heat exchangers." Renewable Energy **97**: 65-76.
- Jensen, M. V. (2014). Seasonal pit heat storage - Guidelines for materials & construction. IEA-SHC Task 45.
- Johansson, P.-O., K. Jonshagen and M. Genrup (2009). Influence of district heating temperature level on a CHP station. Proceedings of ECOS 2009 (22nd International Conference on Efficiency, Cost, Optimization, Simulation and Environmental Impact of Energy Systems), Foz do Iguaçu, Brazil.
- Johansson, P.-O., P. Lauenburg and J. Wollerstrand (2009). Improved cooling of district heating water in substations by using alternative connection schemes. 22nd International Conference on Efficiency, Cost, Optimization, Simulation and Environmental Impact of Energy Systems, Foz do Iguaçu, Paraná, Brazil, Proceedings of ECOS 2009.
- Kabus, F., G. Möllmann, F. Hoffman and J. Bartels (2006). TWO-YEAR EXPERIENCE IN THE OPERATION OF AN AQUIFER THERMAL ENERGY STORE BASED ON SURPLUS HEAT ARISING FROM A GAS AND STEAM COGENERATION PLANT AT NEUBRANDENBURG / NE GERMANY. Tenth International Conference on Thermal Energy Storage. New Jersey, USA.
- KLD (2009). Forskrift om gjenvinning og behandling av avfall (avfallsforskriften). Kap. 9.
- Knowles, J. (2011). Introduction to small and micro combined heat and power (CHP) systems. Small and micro combined heat and power (CHP) systems. R. Beith, Woodhead.
- Kolb, M. (2015). Smart thermal grids: operational experience with low-temperature grids in Zurich. Geothermal ERA-NET - Joint activity Meeting in Geneva, October 30, 2015.
- Lanzini, A., H. Madi, V. Chiodo, D. Papurello, S. Maisano, M. Santarelli and J. Van herle (2017). "Dealing with fuel contaminants in biogas-fed solid oxide fuel cell (SOFC) and molten carbonate fuel cell (MCFC) plants: Degradation of catalytic and electro-catalytic active surfaces and related gas purification methods." Progress in Energy and Combustion Science **61**: 38.
- Lauenburg, P. (2016). 11 - Temperature optimization in district heating systems A2 - Wiltshire, Robin. Advanced District Heating and Cooling (DHC) Systems. Oxford, Woodhead Publishing: 223-240.
- Lennermo, G., P. Lauenburg and L. Brand (2014). Decentralised heat supply in district heating systems - implications of varying differential pressure. The 14th International Symposium on DH and Cooling, Stockholm, Sweden.
- Lennermo, G., P. Lauenburg and L. Brange (2016). Små Värmekällor, Energiforsk.
- Lindkvist, H. and H. Walletun (2005). Teknisk utvärdering av gamla och nya fjärrvärmecentraler i slagsta. Svensk Fjärrvarme. **No Report FoU 2005:120**.
- Lindståhl, H. (2017). Tekniska verken - Bygger världens mest resurseffektiva region. Tekniska Verken. Energiforsk Workshop - Värmelagring för fjärrvärmesystem.
- Line, T. (2013). Ultra-lavtemperert nærvame. VVS-konferansen, Stavanger, Norway.
- Lund, H., S. Werner, R. Wiltshire, S. Svendsen, J. E. Thorsen, F. Hvelplund and B. V. Mathiesen (2014). "4th Generation District Heating (4GDH): Integrating smart thermal grids into future sustainable energy systems." Energy **68**: 1-11.
- Lundh, M. and J. O. Dalenbäck (2008). "Swedish solar heated residential area with seasonal storage in rock: Initial evaluation." Renewable Energy **33**(4): 703-711.

- Mangold, D. and L. Deschaintre (2012). Seasonal Thermal Energy Storage - Report on state of art and necessary further R+D. IEA-SHC Task 45.
- Midttømme, K., R. Ramstad and J. Müller (2015). Geothermal Energy - Country Update for Norway. World Geothermal Congress, Melbourne, Australia.
- NGU (2017). Oversikt over større grunnvarmeanlegg i Norge. Grunnvarmeanlegg_2017.04.24.pdf. <https://www.ngu.no/fagomrade/grunnvarme>.
- Nilsson, J., L. Hargö, J. Cygnaeus, O. Räftegård and M. Rosén (2016). Fastighetsnära säsongslagring av fjärrvärme, Energiforsk.
- Norconsult (2014). Energistrategi for Furuset: Analyse av desentralisert løsning for energiforsyning.
- Nord, N., D. Schmidt, A. Kallert and S. Svendsen (2016). Improved Interfaces for Enabling Integration of Low Temperature and Distributed Heat Sources – Requirements and Examples. CLIMA 2016 - proceedings of the 12th REHVA World Congress, Aalborg, Denmark.
- Obernberger, I., H. Carlsen and F. Biedermann (2003). State of the Art and Future Developments Regarding Small-Scale Biomass CHP Systems With Special Focus on ORC and Stirling Engine Technologies. International Nordic Bioenergy Conference 2003. Finland.
- Olsen, P. K., C. H. Christiansen, M. Hofmeister, S. Svendsen, J.-E. Thorsen, O. Gudmundsson and M. Brand (2014). Guidelines for Low-Temperature District Heating. EUDP 2010-II: Full-Scale Demonstration of Low-Temperature District Heating in Existing Buildings.
- Persson, T., O. Stavset, R. K. Ramstad, M. J. Alonso and K. Lorenz (2016). Software for modelling and simulation of ground source heating and cooling systems. Trondheim, Norway, SINTEF Energy Research, Efficient Energy Use.
- Pettersen, J. E. (2010). Vannrapport 115 Forebygging av legionellasmitte - en veiledning. Nasjonalt folkehelseinstitutt.
- Prando, D., M. Renzi, A. Gasparella and M. Baratieri (2015). "Monitoring of the energy performance of a district heating plant based on biomass boiler and ORC generator." Applied Thermal Engineering 79: 9.
- Ramstad, R. K. (2011). Grunnvarme i Norge - kartlegging av økonomisk potensial. Oppdragsrapport, NVE. Rapport nr 5/2011.
- Reuss, M. (2016). Solar District Heating - an Innovative Approach of an Established Technology. Bavarian Center for Applied Energy Research. Solar District Heating - Mikkeli, Finland.
- Rohde, D., T. Andresen and N. Nord (2016). Interaction Between a Building Complex with an Integrated Thermal Energy System and a District Heating System. CLIMA 2016 - proceedings of the 12th REHVA World Congress, Aalborg, Denmark.
- Rohde, D., M. Bantle, T. Andresen and N. Nord (2015). Operation documentation of an integrated thermal energy system for a building complex. The 24th IIR International Congress of Refrigeration, Yokohama, Japan.
- Rosenberg, M. (2010). Kostnader for fjernvarmeutbygging. Norsk Fjernvarme.
- Salom, J., A. J. Marsal, J. Candanedo, J. Widén, K. B. Lindeberg and I. Sartori (2013). ANALYSIS OF LOAD MATCH AND GRID INTERACTION INDICATORS IN NET ZERO ENERGY BUILDINGS WITH HIGH-RESOLUTION DATA, IEA Task 40/Annex 52 Towards Net Zero Energy Solar Buildings.
- Schmidt, T., D. Mangold and H. Müller-Steinhagen (2003). Seasonal thermal energy storage in Germany. ISES Solar World Congress 2003. Göteborg, Sweden.
- Sibbitt, B., D. McClenahan, R. Djebbar, J. Thornton, B. Wong, J. Carriere and J. Kokko (2012). "The Performance of a High Solar Fraction Seasonal Storage District Heating System – Five Years of Operation." Energy Procedia 30: 856-865.
- Simonsen, I. (2011). 552.455 Vannbaserte solfangere. Funksjon og energiutbytte. SINTEF Buildings And Infrastructure.
- Simrader, G., R. Krawinkler and G. Trnka (2006). Micro CHP systems: State-of-the-Art, Austrian Energy Agency.
- Skreiberg, Ø. (2011). Small-scale biomass CHP recommendations for Norway. KRAV - Enabling small-scale biomass CHP in Norway, SINTEF Energi.

- SSB. (2017). "Fjernvarme, 2015 - Fjernvarmebalanse. GWh." Retrieved 18.04.2017, from <https://www.ssb.no/energi-og-industri/statistikker/fjernvarme/>.
- SSI (2000). Legionella i varmt brugsvand. Statens Serum Institut.
- Statsbygg (2017). Campus Evenstad JAKTEN PÅ ET NULLUTSLIPPSBYGG (ZEB-COM), Statsbygg.
- Stene, J. (2009). 552.403 Varmepumper i bygninger. Funksjonsbeskrivelse. SINTEF Buildings And Infrastructure.
- Stene, J. (2015). Kombinert kjøle- og varmepumpeanlegg for datakjøling og høytemperatur varmegjenvinning ved NTNU Gløshaugen, Trondheim. Norsk Kjøleteknisk Møte, Bergen, Norway.
- Tecalia (2015). D5.5: Design guidelines for STES system for all europe. <http://www.einstein-project.eu/>.
- Yang, X., H. Li and S. Svendsen (2016). "Evaluations of different domestic hot water preparing methods with ultra-low-temperature district heating." *Energy* 109: 248-259.



VISION:

**«Sustainable
neighbourhoods
with zero
greenhouse gas
emissions»**



Research Centre on
ZERO EMISSION
NEIGHBOURHOODS
IN SMART CITIES



<https://fmezen.no>